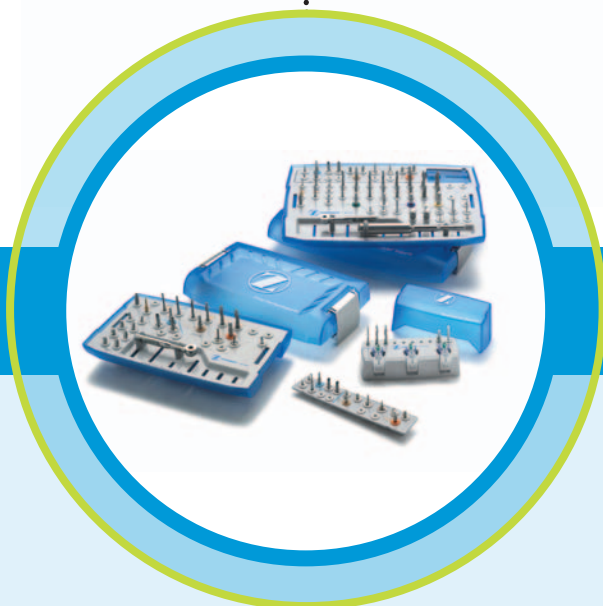
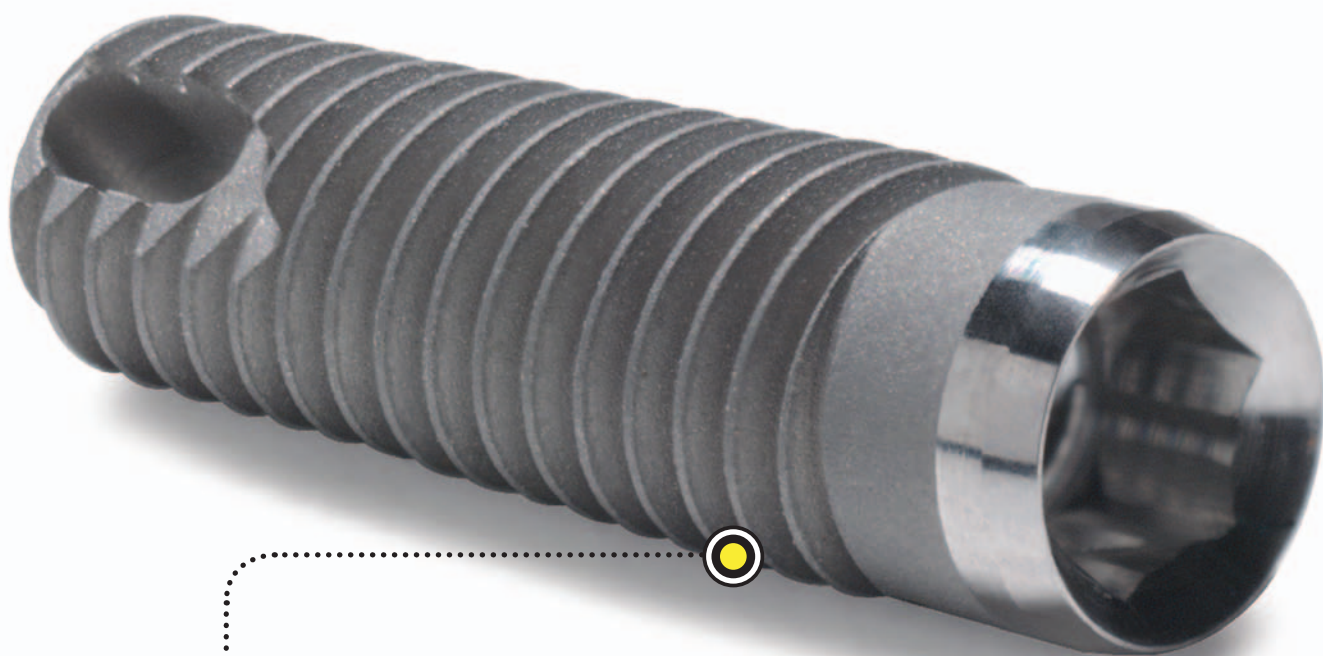
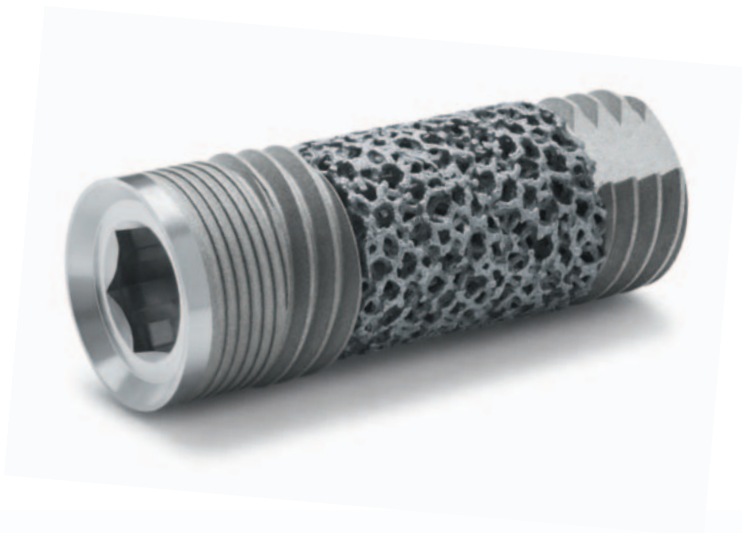




Tapered Screw-Vent[®] Implant System



Surgical Manual



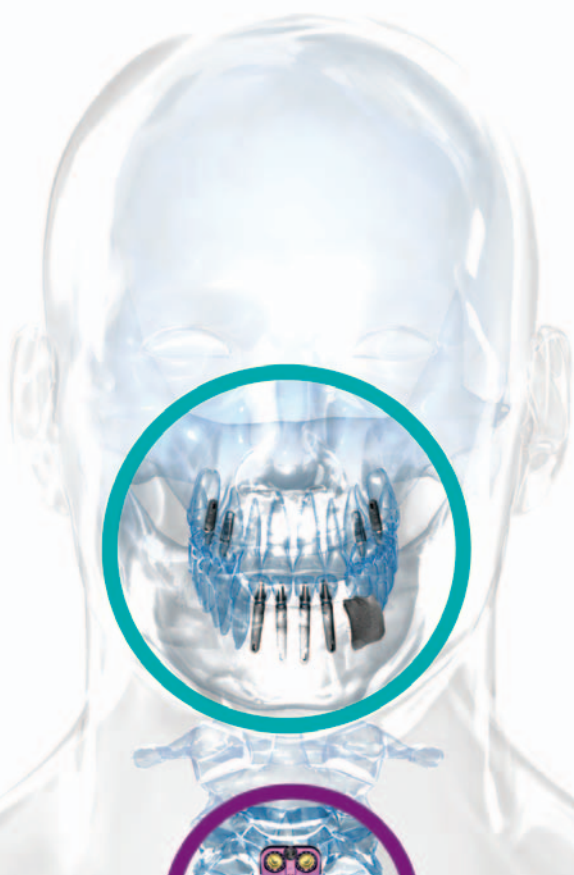
zimmer | dental

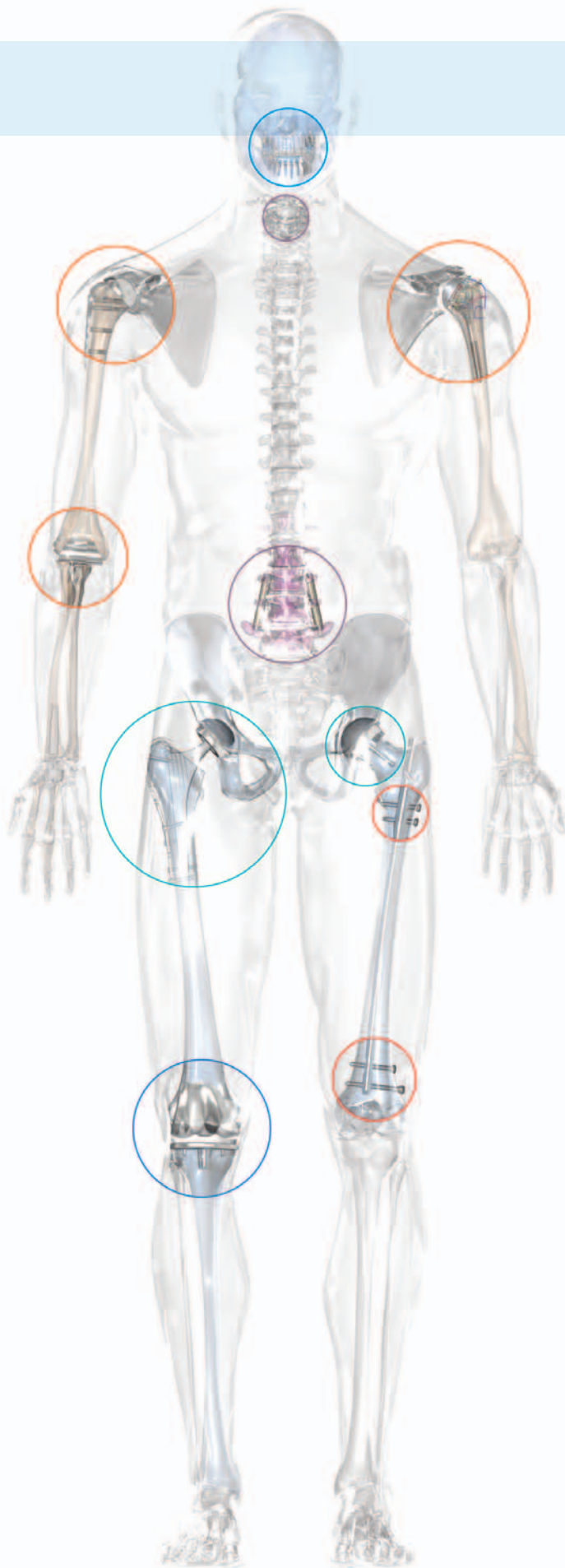
NO ONE KNOWS BONE LIKE ZIMMER

This Surgical Manual is designed to provide information regarding the pre-surgical and surgical procedures applicable to implants in the *Tapered Screw-Vent* Implant System, including *Trabecular Metal*,™ *AdVent*® and *Zimmer*® One-Piece Implants.

Zimmer Dental provides a comprehensive portfolio of innovative implant technologies designed to meet a broad range of clinical needs. For decades, Zimmer Dental has gained the trust of thousands of clinicians worldwide by helping them to **deliver successful patient outcomes**. Zimmer continues to be a market leader in the development of world-class implantology products, practice partnerships and educational programs—all focused on **empowering clinicians** and revolutionizing implant dentistry. Headquartered near San Diego in Carlsbad, California, Zimmer Dental has direct subsidiary operations in Australia, Canada, China, France, Germany, Israel, Italy and Spain, with a global network of **distributors in more than 60 countries worldwide**.

Zimmer Holdings, Inc. (NYSE and SWX: ZMH), parent company of Zimmer Dental Inc., is a worldwide leader in the design, development, manufacturing and marketing of reconstructive orthopaedic implants, including joint and dental, spinal implants and trauma products, and related orthopaedic surgical products. Founded in 1927, Zimmer is headquartered in Warsaw, Indiana, with direct operations in more than 25 countries and products currently sold and represented in more than 100 countries. Nearly 8,000 employees worldwide proudly share a vision of improving the quality of patients' lives every day.





○ DENTAL

○ EXTREMITIES

○ SPINE

○ HIPS

○ KNEES

○ TRAUMA

TABLE OF CONTENTS

OVERVIEW

GENERAL INFORMATION	PAGE
PRE-SURGICAL PLANNING	3
○ TRADITIONAL SURGERY	5
○ ZIMMER® GUIDED SURGERY	7
○ BONE DENSITY CLASSIFICATION	8

IMPLANT DESIGN & SPECIFICATIONS

○ INDICATIONS FOR USE AND GENERAL INFORMATION	10
○ CRESTAL OPTIONS	11
○ <i>TRABECULAR METAL</i> IMPLANTS	12
○ <i>TAPERED SCREW-VENT</i> IMPLANTS	13
○ ZIMMER ONE-PIECE IMPLANTS	15
○ <i>ADVENT</i> IMPLANTS	16
○ MATERIALS AND SURFACES	17
○ IMPLANT THREADS AND MICROGROOVES	18
○ IMPLANT PLATFORMS	19
○ <i>PLATFORM PLUS™</i> TECHNOLOGY	23

IMPLANT SELECTION GUIDELINES

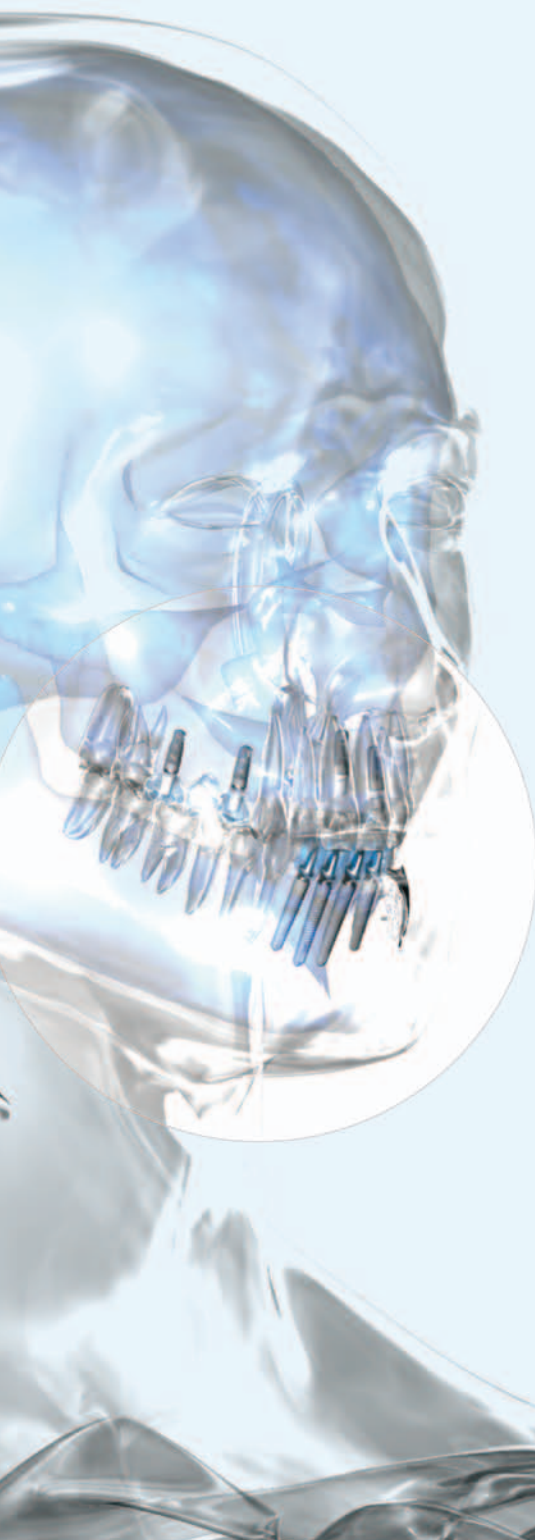
○ IMPLANT CHART	25
○ ANATOMICAL CRITERIA	27

ZIMMER® INSTRUMENT KIT SYSTEM

○ SYSTEM OVERVIEW	31
○ GENERAL SURGICAL INSTRUCTIONS	32
○ CLEANING & STERILIZATION GUIDELINES	33
○ COLOR REFERENCE CHARTS	35
○ <i>TAPERED SCREW-VENT</i> SURGICAL KIT	37
○ ZIMMER GUIDED SURGERY DRILL MODULE	38
○ ZIMMER ONE-PIECE UPGRADE	39
○ ZIMMER ONE-PIECE SURGICAL KIT	40
○ ZIMMER® DRILL STOP KIT	41

DRILLING SEQUENCE

○ <i>TAPERED SCREW-VENT, TRABECULAR METAL</i> AND <i>ADVENT</i> IMPLANTS	44
○ ZIMMER ONE-PIECE IMPLANTS	45



SURGICAL PROCEDURES

TRADITIONAL SURGICAL PROCEDURES

TRABECULAR METAL, TAPERED SCREW-VENT AND ADVENT IMPLANTS

- SITE PREPARATION 47
- SOFT AND DENSE BONE PROTOCOLS 51
- COLLAR DEPTH ADJUSTMENT 52
- IMPLANT PLACEMENT 53
- ONE- AND TWO-STAGE PROTOCOLS 54
- HEALING COLLAR SELECTION GUIDE 57

ADVENT IMPLANTS

- ALIGNING THE IMPLANT AND PLACEMENT OF HEALING COMPONENTS 59
- HEALING PHASE 60

ZIMMER ONE-PIECE SURGICAL PROCEDURES

- INITIAL SITE PREPARATION – ALL DIAMETERS 61
- 3.0mmD IMPLANT PROCEDURE AND PLACEMENT 62
- 3.7mmD AND 4.7mmD IMPLANT PROCEDURE AND PLACEMENT 64

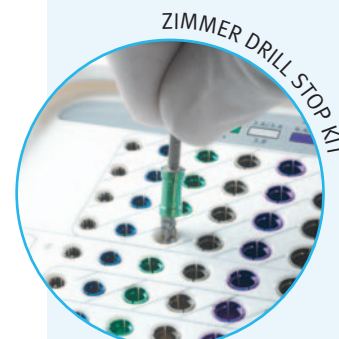
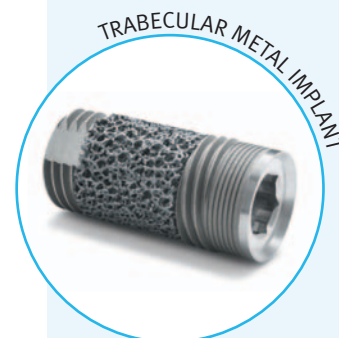
ZIMMER GUIDED SURGERY SURGICAL PROCEDURES

- OVERVIEW 66
- GUIDED SURGERY MODULE AND SURGICAL DRILLS 67
- TUBE ADAPTER KIT 68
- SURGICAL TECHNIQUE 69

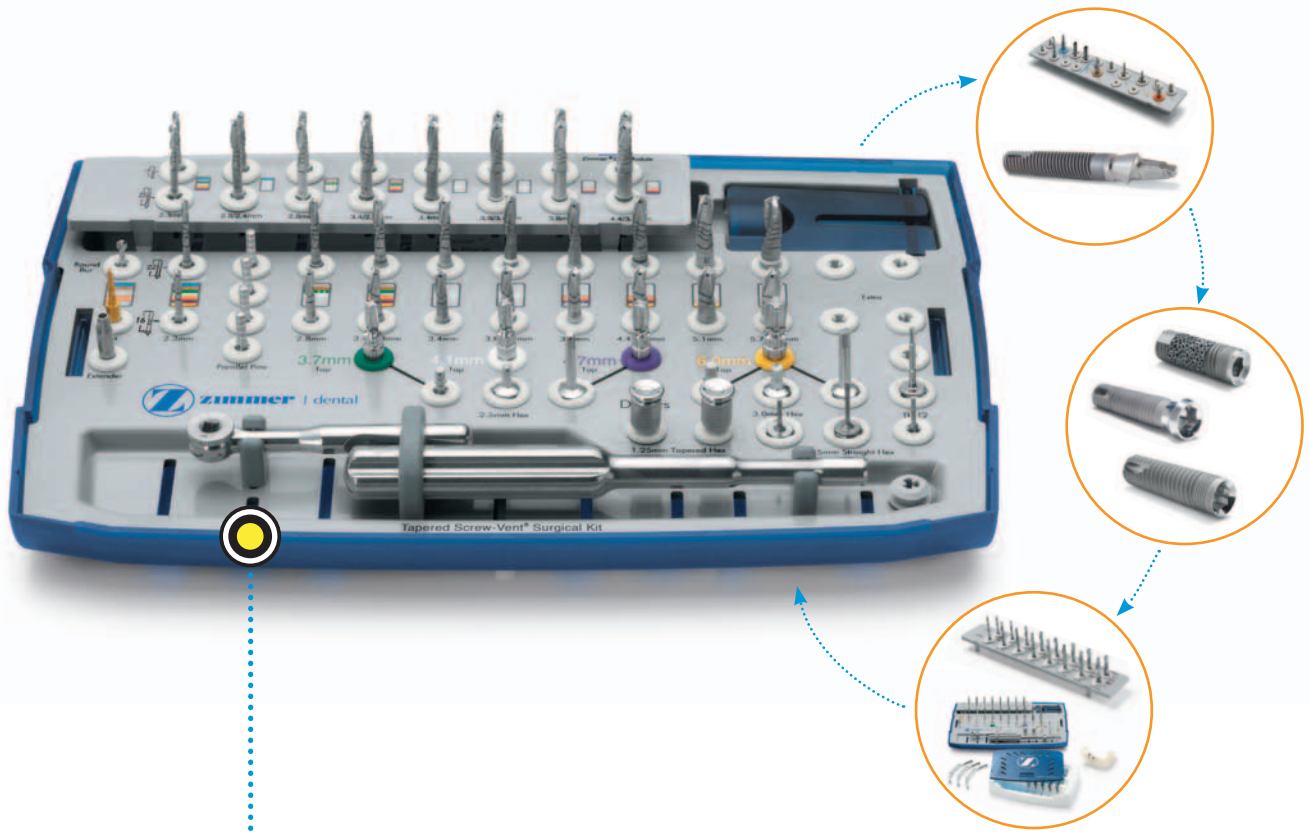
APPENDIX

PACKAGING INSTRUCTIONS FOR USE

- TRABECULAR METAL, TAPERED SCREW-VENT AND ADVENT IMPLANTS 75
- REFERENCES 77



OVERVIEW



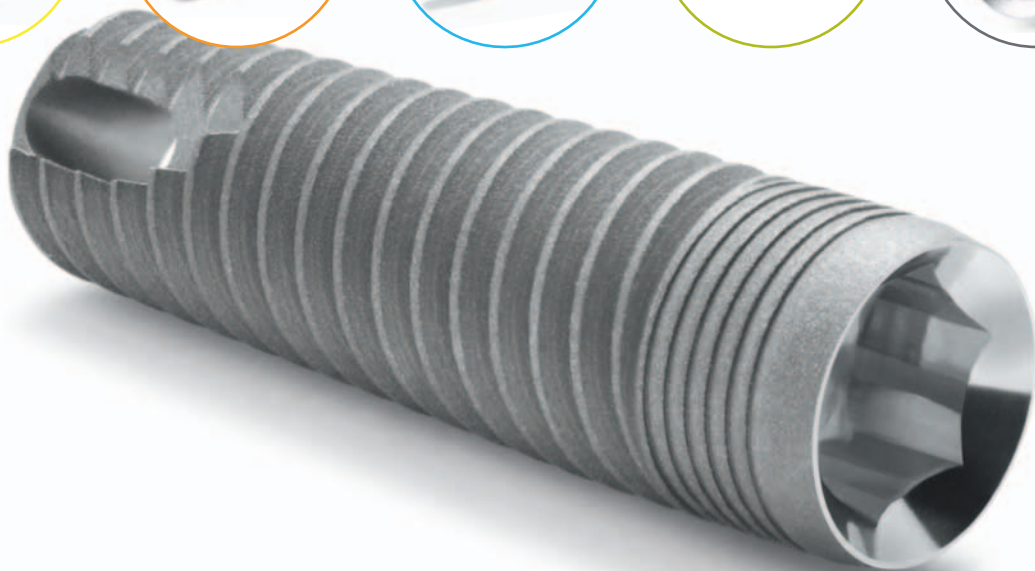
GENERAL INFORMATION

Trabecular Metal and Tapered Screw-Vent Implants are designed to be placed at bone level. The occlusal aspect (platform) of the implant is the receiving area for the prosthetic component of the restoration. This area of the implant is placed level with the crest of the bone when following standard implant placement procedures, although variations of placement have been clinically accepted. The implant neck and body are placed sub-crestally. The sub-crestal portion of the implant has the *MTX*[®] Microtextured Surface or an *MTX* Surface in combination with a *Trabecular Metal* Material or *MP-1*[®] HA Surface mid-section. Select implants are offered with and without crestal microgrooves and machined collar or texturing to the top to maximize flexibility in a variety of clinical conditions.



The **Zimmer One-Piece Implant** is placed transmucosally in a one-stage procedure. The integrated, pre-contoured abutment receives the prosthetic restoration and the *MTX* Microtextured Surface and a portion of the machined neck are placed sub-crestally.

The **AdVent Implant** is designed to be placed transmucosally in a one-stage surgical procedure. The fluted machined neck functions as the transgingival extension of the implant receiving the prosthetic component of the restoration. The *MTX* Microtextured Surface or combination *MTX* and *MP-1* HA Surface portion of the implant (that includes the threaded area) is placed sub-crestally.



PRE-SURGICAL PLANNING

TEAM APPROACH

Successful implant treatment requires the coordinated efforts of several dental professionals – the restorative dentist, the surgeon (prosthodontist, periodontist, oral surgeon or general dentist), the laboratory technician and the dental hygienist. By holding a pre-surgical conference, these individuals are able to develop an appropriate treatment strategy. This provides a balance between esthetic, functional and surgical goals. In addition, the coordinated approach ensures that the treatment approach is complete, guarding against omission of important technical considerations such as the use of a surgical guide for implant positioning, and the biomechanical boundaries of the final prosthesis.



PATIENT EVALUATION AND SELECTION

- Take a general medical history.
- Undertake a psycho-social evaluation.
- Explore indications and contraindications.
- Determine anatomical landmark considerations related to implant positioning.
- Determine feasible vertical dimensions.
- Consider biomechanical requirements of final restoration.
- Discuss treatment objectives and patient's expectations.
- Perform various radiographic and scanning evaluations.

PRE-SURGICAL PLANNING GUIDELINES

Proper stress distribution is essential to the long-term success of both the prosthesis and the implant. Overload is one of the key contributors to implant failure and is especially important in the cuspid and molar regions.

To minimize excessive loads, the following guidelines apply:

- Decrease occlusal forces transferred to the implant by reducing the occlusal table.
- Distribute occlusal forces optimally by maximizing the number of implants used to support the prosthesis.
- Place the largest implant possible that meets anatomical and restorative needs.
- Position and incline the implants to ensure good prosthetic design, function, and esthetics. Direct forces of occlusion along the long axis of the implant.
- Strengthen the overall treatment plan in patients with a heavy muscular profile or whose occlusal analysis indicates a strong bite by using the largest size implants, maximizing the number of implants and abutments, minimizing the use of cantilevers, and placing abutments for the most even distribution of occlusal loads.
- Take into consideration the opposing dentition in the design of the proposed restoration.

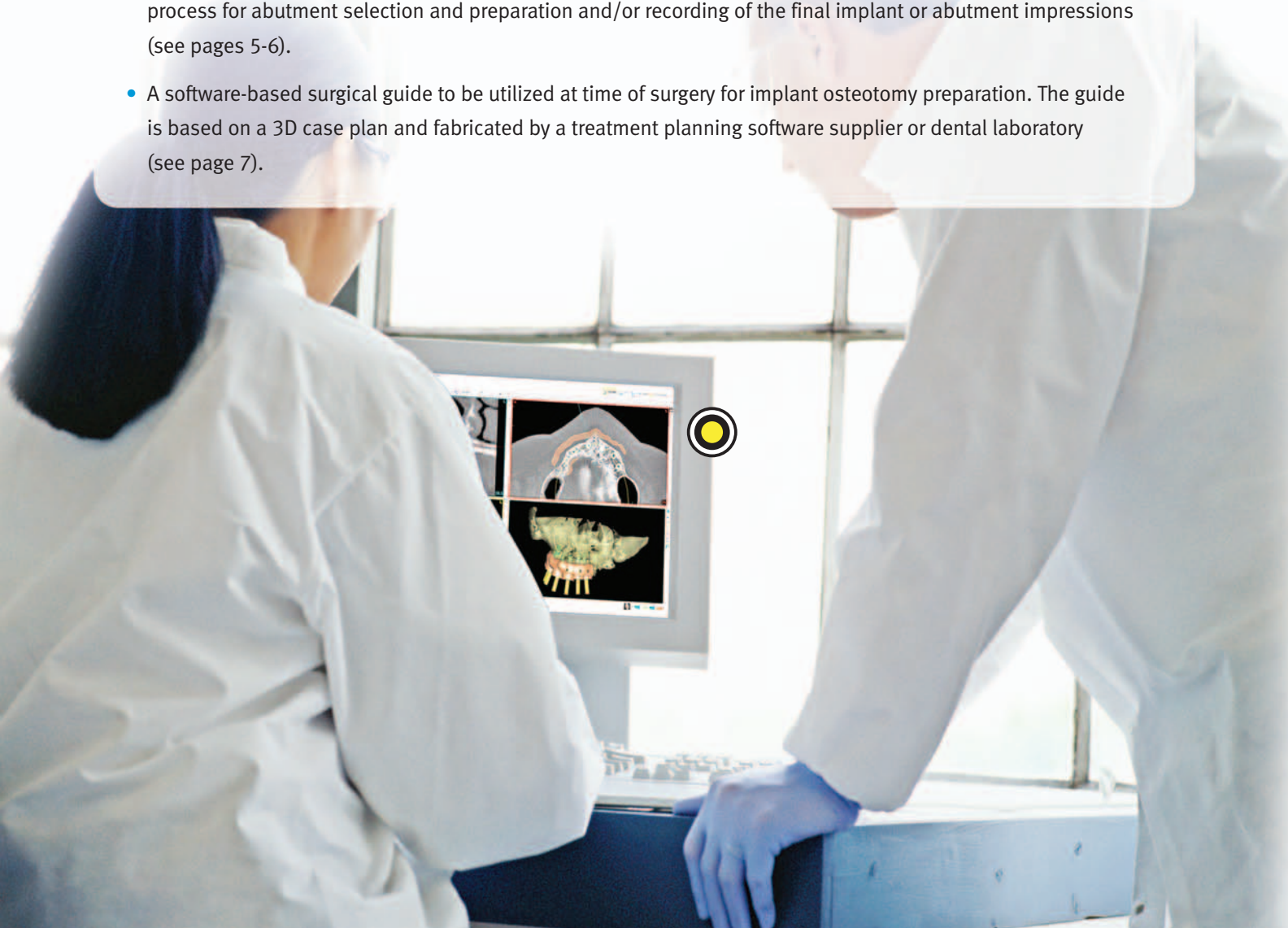
DIAGNOSTIC AND SURGICAL GUIDES

Implant dentistry is guided by the restorative aspect of the procedure. Therefore, it is a prerequisite to evaluate the position of the surrounding anatomical landmarks and natural teeth relative to the proposed area for implant placement.

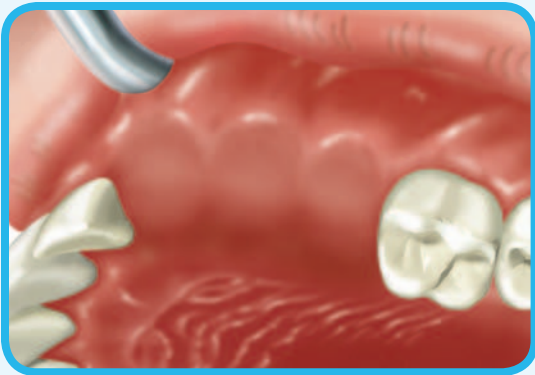
RULE OF "P" – Proper Pre-treatment Planning Prevents Prosthetic Problems.

Fabricate diagnostic casts with a wax-up of the proposed position of the teeth in the implant prosthesis. The Implant Team will utilize the diagnostic casts to fabricate the following, if required:

- Diagnostic guide with included markers for a variety of radiological exams – panoramic, periapical, computerized tomography (CT/CBCT scan), etc. These exams can supply the team with information regarding bone quality and quantity, location of vital structures (mental nerve canal, sinus cavities, labial or lingual bone contour, and surrounding roots if present), and soft tissue height relative to the occlusal plane (see pages 5-6).
- A traditional, model-based surgical guide to be utilized at time of surgery for implant osteotomy preparation, taking into consideration mesiodistal and buccolingual angulation and placement of the implants while maintaining required distance between the implants. Some surgical guides can be resterilized and used by the restoring clinician to plan the contours of the final prosthesis. The guide may also be used in the decision-making process for abutment selection and preparation and/or recording of the final implant or abutment impressions (see pages 5-6).
- A software-based surgical guide to be utilized at time of surgery for implant osteotomy preparation. The guide is based on a 3D case plan and fabricated by a treatment planning software supplier or dental laboratory (see page 7).



TRADITIONAL SURGERY



FABRICATION OF A DIAGNOSTIC AND SURGICAL GUIDE

RECORDING AN IMPRESSION

Use standard impression techniques to record an impression of the edentulous area with surrounding anatomical landmarks and the opposing arch.

- 1) For partially edentulous areas, make inter-occlusal records of the opposing arches in centric relation.
- 2) For fully edentulous areas, follow standard procedures for fabrication of an occlusal registration rim to create a wax denture try-in.

MOUNTING THE DIAGNOSTIC CASTS

To determine the distance between edentulous areas and opposing dentition, mount diagnostic casts utilizing the inter-occlusal records.

For partially edentulous arches, fabricate a diagnostic wax-up of the edentulous area using denture teeth or standard crown and bridge waxing techniques.

For fully edentulous arches, use an occlusal registration rim to make a bite registration, then create a patient-approved wax denture tooth try-in.

DUPLICATING THE DIAGNOSTIC WAX-UP

Discuss surgical and restorative component options with the implant team prior to preparing the cast and wax-up for duplication.

Use an impression tray with alginate impression material to make an impression of the cast with incorporated wax-up of teeth and surrounding lost soft tissue. Fill the impression with stone and allow to harden.

Use the cast with diagnostic wax-up to fabricate a diagnostic, radiographic, surgical or alternatively a multi-function guide.

FABRICATING THE CLEAR GUIDE

Create a transparent guide using one of the following procedures:

- 1) A clear plastic 0.5mm thick sheet is vacuum-formed over the duplicate stone cast of the tooth wax-up. Trim the guide according to clinical requirements. The vacuform can be used in its hollow version or using autopolymerizing or light cure acrylic to fill in areas previously occupied by wax and denture teeth.
- 2) Use a denture duplicator to create a clear version of the patient's current or new denture.



PLACING THE RADIOGRAPHIC MARKERS

Using metal radiographic markers when planning for a CT or similar type of scan **is not recommended**. Dimensionally calibrated metal ball bearings or an orthodontic wire will cause a sunburst or scatter effect rendering the scan unreadable.

Place material such as gutta percha or a mixture of radiographic powder (e.g., barium chloride powder) and resin into pre-drilled diagnostic grooves or holes in the guide. The hole or markers should be placed inclusive of the incisal, cingulum or occlusal height of replacement teeth, taking into consideration the vacuform sheet thickness and the point in contact with the soft tissue. Metal markers can be used with standard scan procedures such as a panoramic or periapical.



SEATING THE CLEAR GUIDE

Place the guide with included radiographic markers into the patient's mouth, lock into position by engaging the undercut created by the height of contour of the surrounding natural teeth.

Make the required scan best suited for the proposed case design to acquire a working knowledge of the anatomical limitations in the areas of proposed implant placement.



MAKING THE REQUIRED MEASUREMENTS

The scan is used in conjunction with overlay templates of the implant design to plan the case. Radiographic markers can help the clinician determine:

- Height of the teeth to be replaced.
- Thickness of the soft tissue (by subtracting the end of the marker from the start of the bone).
- Position of the restorative margin.
- Number of implants.
- Length of the implant.
- Diameter of implant.
- Inter-implant space.



TRIMMING THE CLEAR GUIDE

Remove the material from the radiographic/diagnostic guide in the area that is planned for surgery.

The clinician responsible for implant placement determines if they want vertical holes drilled or sections removed from the original guide to assist them in implant placement.

GUIDED SURGERY



FABRICATION OF A DIAGNOSTIC AND SOFTWARE-BASED SURGICAL GUIDE

FABRICATING THE DIAGNOSTIC GUIDE/SCAN PROSTHESIS

A scan prosthesis is generally a radiopaque duplicate of the provisional teeth set-up or patient's existing denture for visibility of the desired tooth location in the CT images and selected case planning software. Follow the software supplier's general scanning instructions including fabrication of the scan prosthesis, patient preparation, positioning, image reconstruction and scanning parameters.



FABRICATING THE SURGICAL GUIDE

A software-based, case-specific surgical guide is fabricated by the software supplier or the dental laboratory.

For more guided surgery technique information, please reference the Zimmer Guided Surgery Technique Guide, P/N 1349 and pages 64-71 in this manual. For detailed surgical guide instructions for use please contact your software and/or surgical guide manufacturer.

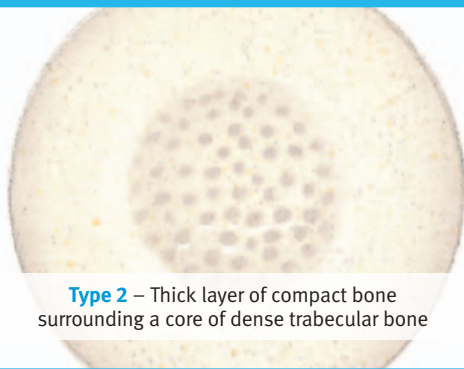


Zimmer Guided Surgery

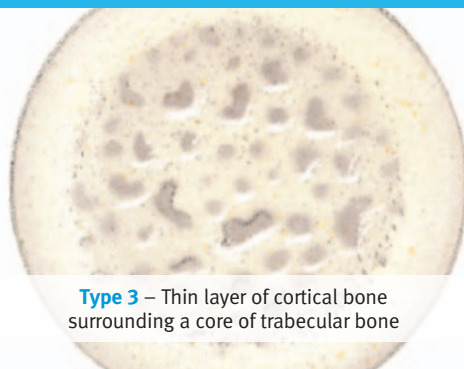
BONE DENSITY CLASSIFICATION



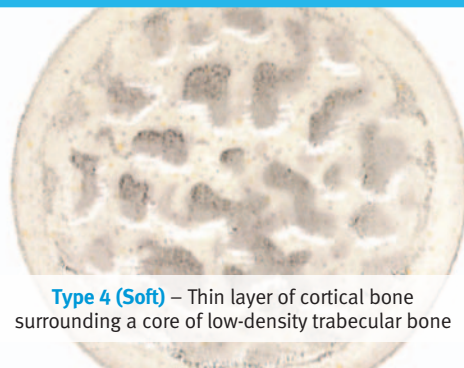
Type 1 (Dense) – Almost entirely homogeneous compact bone



Type 2 – Thick layer of compact bone surrounding a core of dense trabecular bone



Type 3 – Thin layer of cortical bone surrounding a core of trabecular bone



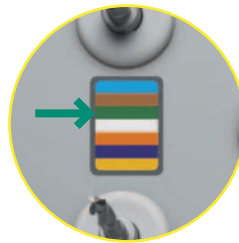
Type 4 (Soft) – Thin layer of cortical bone surrounding a core of low-density trabecular bone

BONE DENSITY CLASSIFICATION

While one method of classifying bone density is shown in the images (left)¹, different combinations of cortical and trabecular bone in varying thicknesses and densities can occur, and these typically differ by jaw location. The clinician is responsible for assessing bone density of the surgical site and choosing the appropriate protocol.

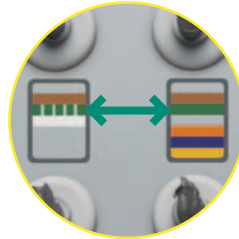
PROTOCOLS FOR VARYING BONE DENSITIES

Many of the protocols in this Surgical Manual include drilling sequences for soft and dense bone. In the soft bone surgical protocol, a straight and somewhat undersized osteotomy is prepared to help enhance initial stability of the implant through lateral bone compression². The dense bone protocol prepares a slightly larger, stepped osteotomy.



PROTOCOL EXAMPLE

Step 1: The 3.7mmD *Tapered Screw-Vent* Implant is color-coded in green. Start with the first green bar on the kit, which indicates the first drill to be used in the drilling sequence for this implant size.

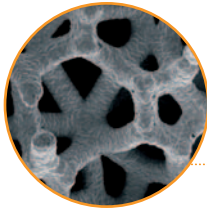


Step 2: Follow the green color bars from left to right. In a soft bone protocol, the dotted green bar represents the final drill. For dense bone, skip the dotted green bar and move on directly to the next solid green bar. The last solid bar in the sequence represents the final drill for dense bone.



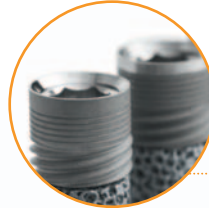
Step 3: When drilling in dense bone, you can optionally use the 3.7mmD cortical bone tap located in a green grommet directly below the last solid green bar in the sequence.

IMPLANT DESIGN & SPECIFICATIONS



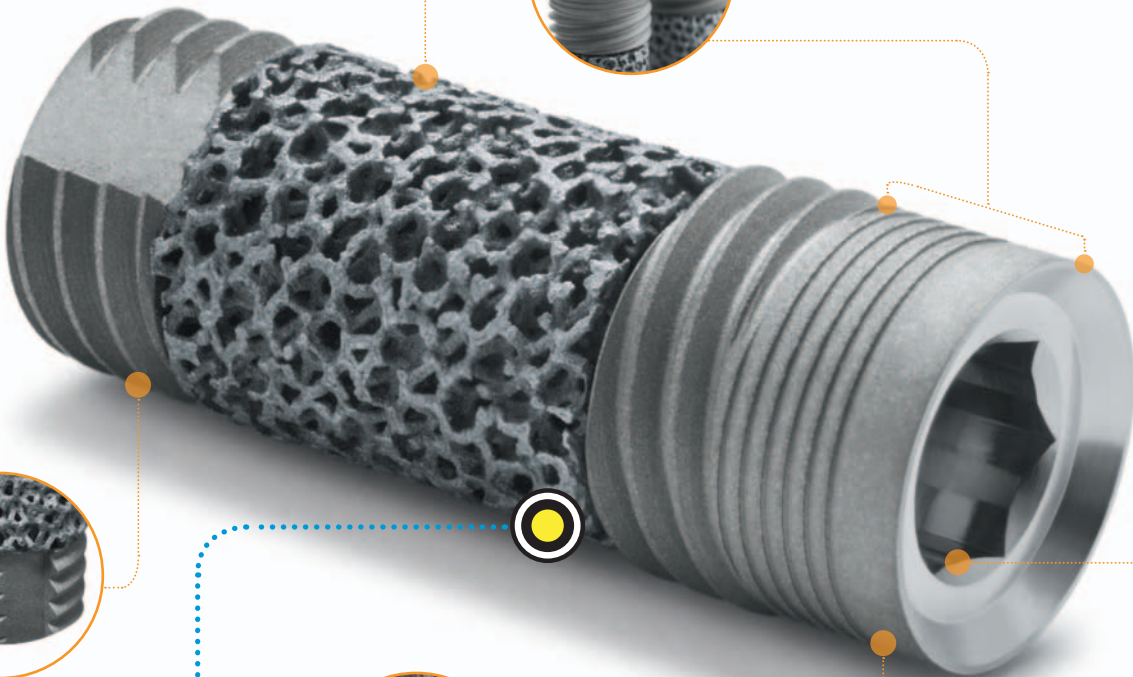
TRABECULAR METAL MATERIAL

The implant's *Trabecular Metal* Material mid-section has been designed to be structurally similar to cancellous bone.³⁻⁶ Zimmer Dental continues to gather data to document the volume and rate of ingrowth and its effects on secondary stability.



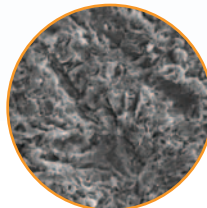
TWO CORONAL SURFACE CONFIGURATIONS

- 0.5mm Machined Titanium (Model TMM, shown in circle, right).
- *MTX* Microtexturing to the top (Model TMT, shown in circle, left).



TAPERED IMPLANT BODY

The tapered titanium alloy body provides the strength of traditional dental implants.⁷⁻¹⁰



MTX SURFACE FOR BONE-TO-IMPLANT CONTACT

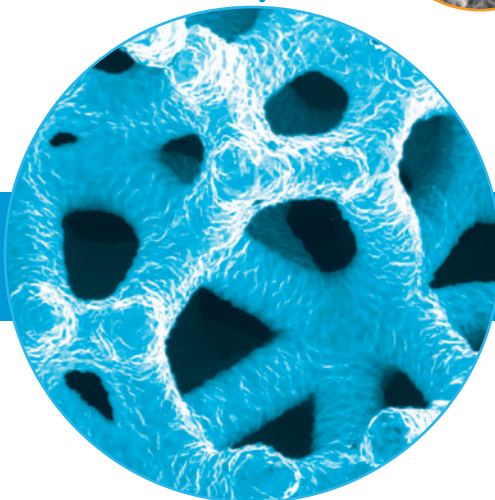
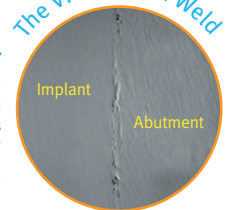
The *MTX* Microtextured Surface has been documented to achieve high levels of bone-to-implant contact.

PLATFORM PLUS TECHNOLOGY

The proprietary internal hex connection, utilized with Zimmer Dental's friction-fit abutments, has been documented to shield crestal bone from concentrated occlusal forces^{11,12} as demonstrated in an *in-vitro* FEA study*

* Results are not necessarily predictive of human clinical results.

The Virtual Cold Weld



INDICATIONS FOR USE

Trabecular Metal Dental Implants are designed for use in the maxilla or mandible for immediate loading or for loading after a conventional healing period. Implants may be used to replace one or more missing teeth. Immediate loading is indicated when there is good primary stability and an appropriate occlusal load. The 4.1mmD *Trabecular Metal* Dental Implants should be splinted to additional implants when used in the posterior region.



Tapered Screw-Vent and AdVent Implants are designed for use in the maxilla or mandible for immediate loading or for loading after a conventional healing period. Implants may be used to replace one or more missing teeth. Immediate loading is indicated when there is good primary stability and an appropriate occlusal load.

Zimmer One-Piece 3.0mmD Implants are indicated for the support and retention of fixed single-tooth and fixed partial denture restorations in the mandibular central and lateral incisor and maxillary lateral incisor regions of partially edentulous jaws. The 3.0mmD *Zimmer One-Piece* Implant must be splinted if two or more are used adjacent to each other, and may be immediately restored with a temporary prosthesis that is not in functional occlusion.

Zimmer One-Piece 3.7mmD and 4.7mmD Implants are designed for use in the maxilla or mandible for immediate loading, or for loading after a conventional healing period. Implants may be used to replace one or more missing teeth. Immediate loading is indicated when there is good primary stability and an appropriate occlusal load.

GENERAL IMPLANT INFORMATION

The implant diameter is the dimension taken from the peak of the widest thread to the same point on the other side of the implant, referred to as the outside dimension of the thread. Sufficient alveolar bone width to surround the implant should be available for placement of the selected diameter (a minimum of 1mm circumferential, or 1.5mm for *Zimmer One-Piece* Implants). In addition, 2mm of bone is recommended beyond the apical aspect of the implant.

BONE-LEVEL IMPLANTS

- *Trabecular Metal* Implants available in several body diameters, including: 4.1mmD, 4.7mmD and 6.0mmD.
- *Tapered Screw-Vent* Implants available in four body diameters: 3.7mmD, 4.1mmD, 4.7mmD and 6.0mmD.

TISSUE-LEVEL IMPLANT

- *AdVent* Implants available in two diameters: 3.7mmD and 4.7mmD.

ONE-PIECE IMPLANT

- *Zimmer One-Piece* Implants available in three body diameters: 3.0mmD, 3.7mmD and 4.7mmD.

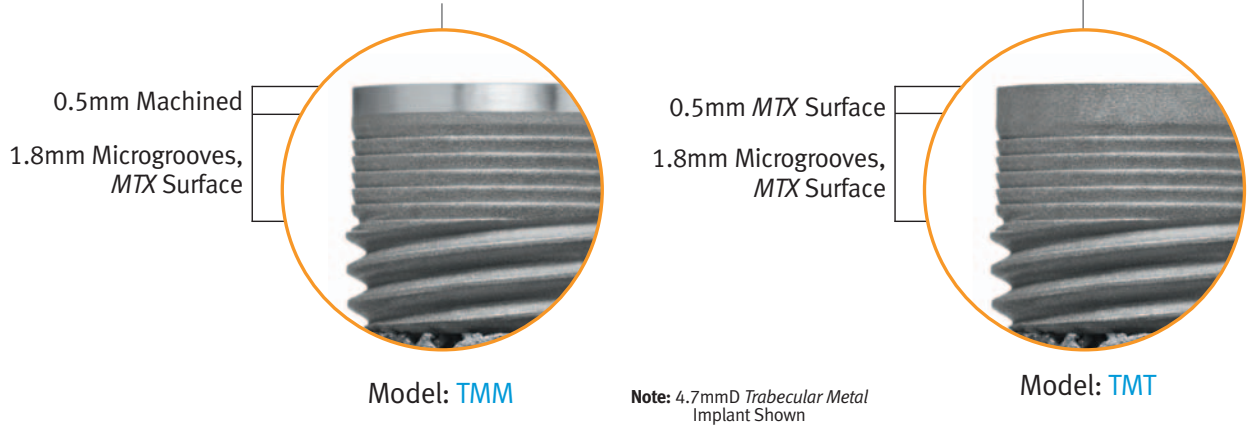


CRESTAL OPTIONS

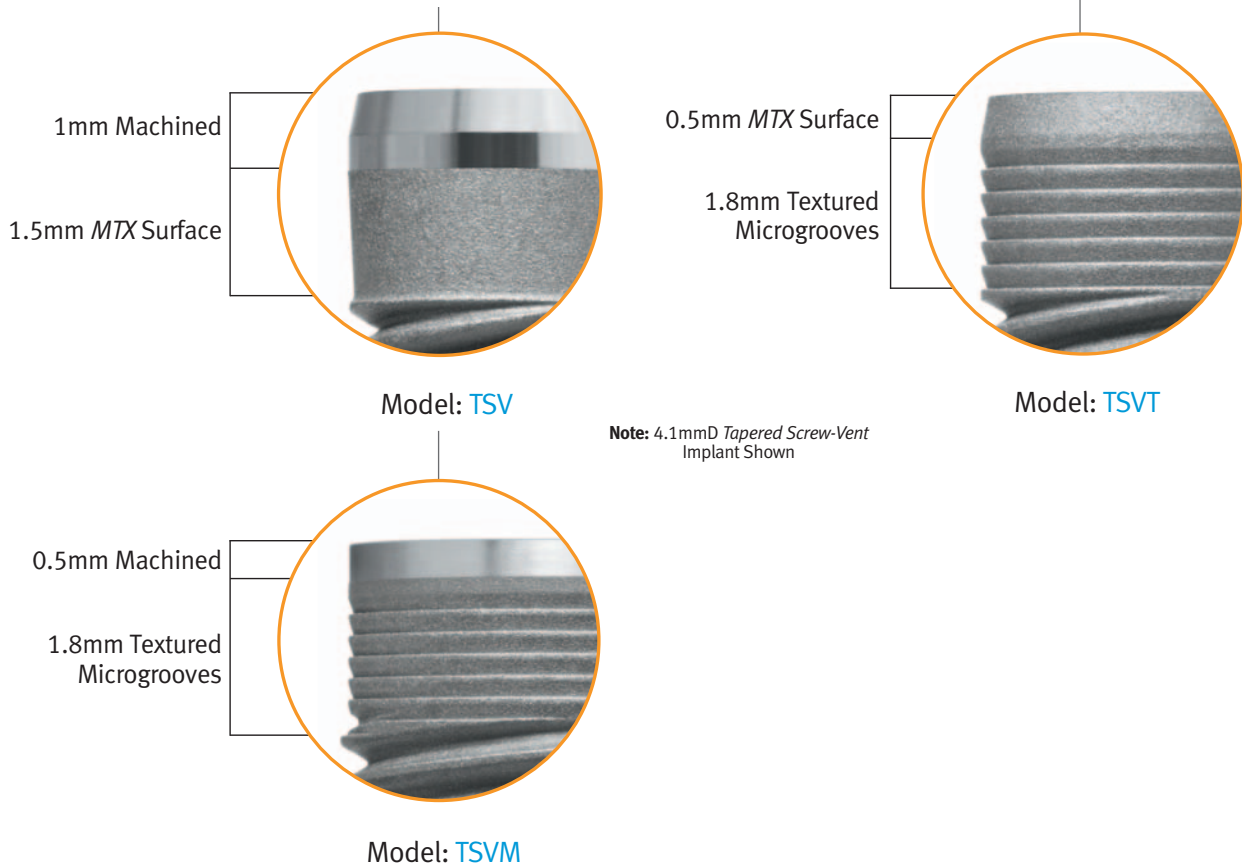
DESIGNED FOR FLEXIBILITY

Trabecular Metal and *Tapered Screw-Vent* Implants are offered with and without crestal microgrooves and machined collar or texturing to the top to maximize flexibility in a variety of clinical conditions. Configurations available on select implants are shown below.

TRABECULAR METAL DENTAL IMPLANT



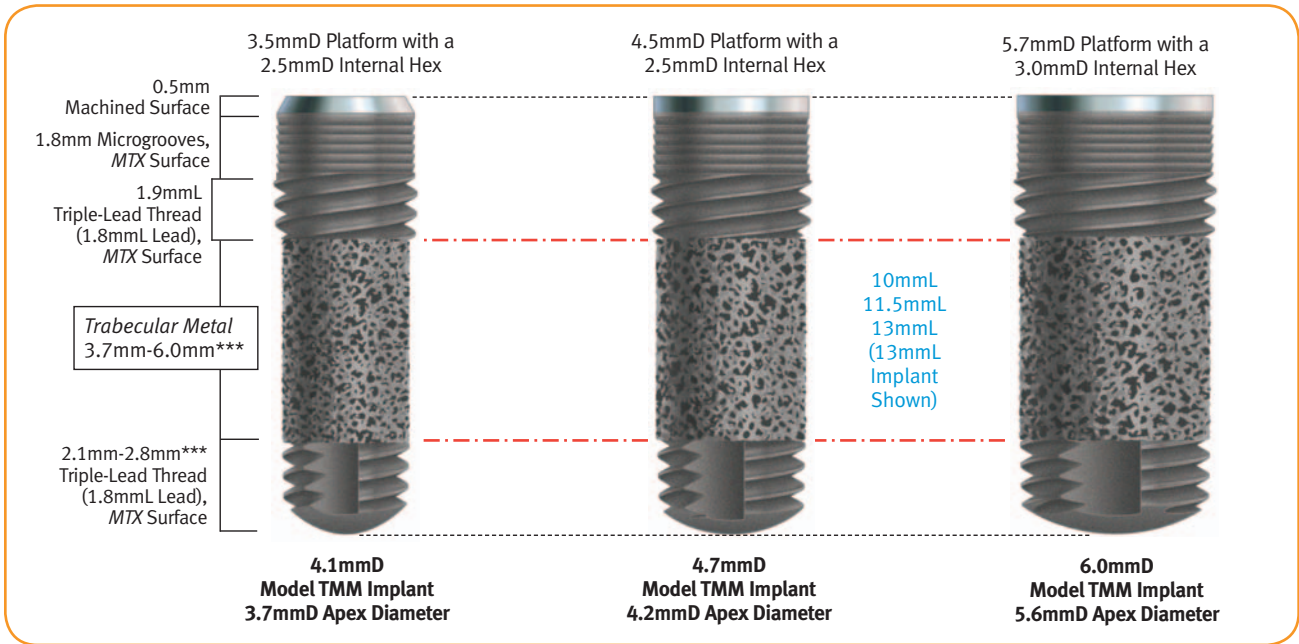
TAPERED SCREW-VENT IMPLANT



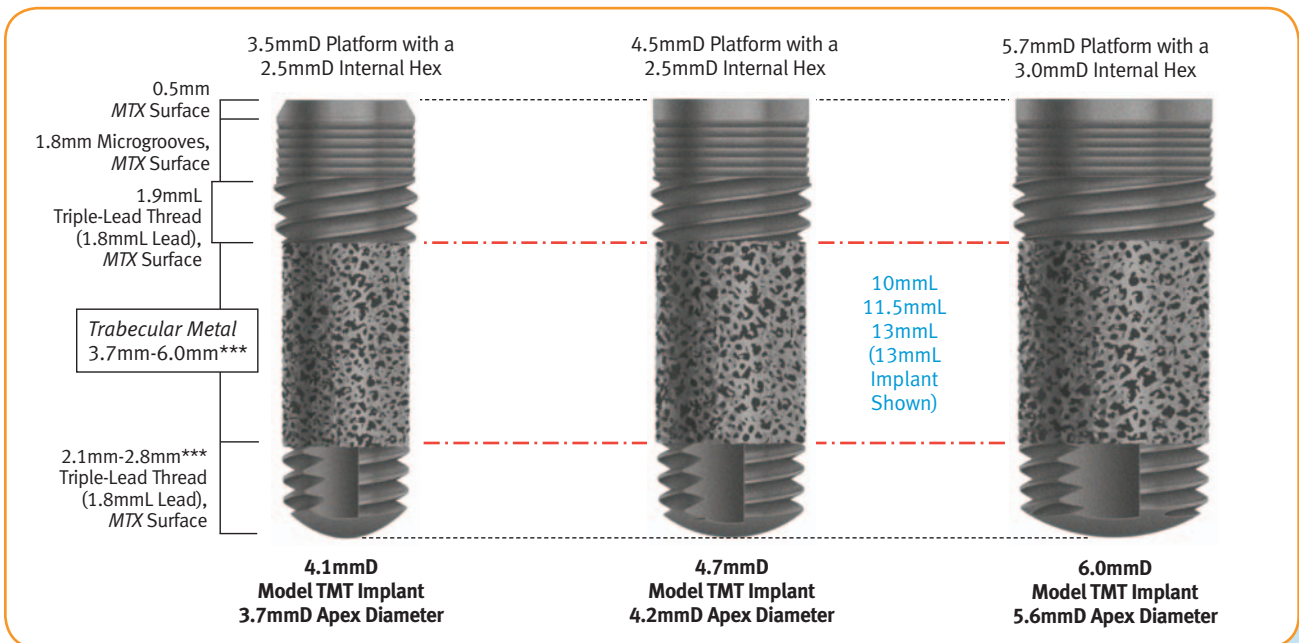
TRABECULAR METAL DENTAL IMPLANTS*

Trabecular Metal Implants have a 0.5mm machined or *MTX* microtextured coronal aspect, followed by 1.8mm of the *MTX* Surface with microgrooves. The six microgrooves are circumferential with a depth of 0.06mm and peak-to-peak width of 0.28mm. Triple-lead threads begin 2.5mm** from the top of the implant and continue to the apex with the exception of the *Trabecular Metal* Material mid-section. The degree of body taper varies between 1.5° and 2.0°, depending on implant length, to ensure that the apical diameter is consistent among all 3 implant lengths. Therefore, the shorter the implant, the greater the degree of taper.

TRABECULAR METAL DENTAL IMPLANT - 0.5MM MACHINED COLLAR WITH MICROGROOVES (MODEL TMM)



TRABECULAR METAL DENTAL IMPLANT - FULLY TEXTURED WITH MICROGROOVES (MODEL TMT)



* Not available in all countries.

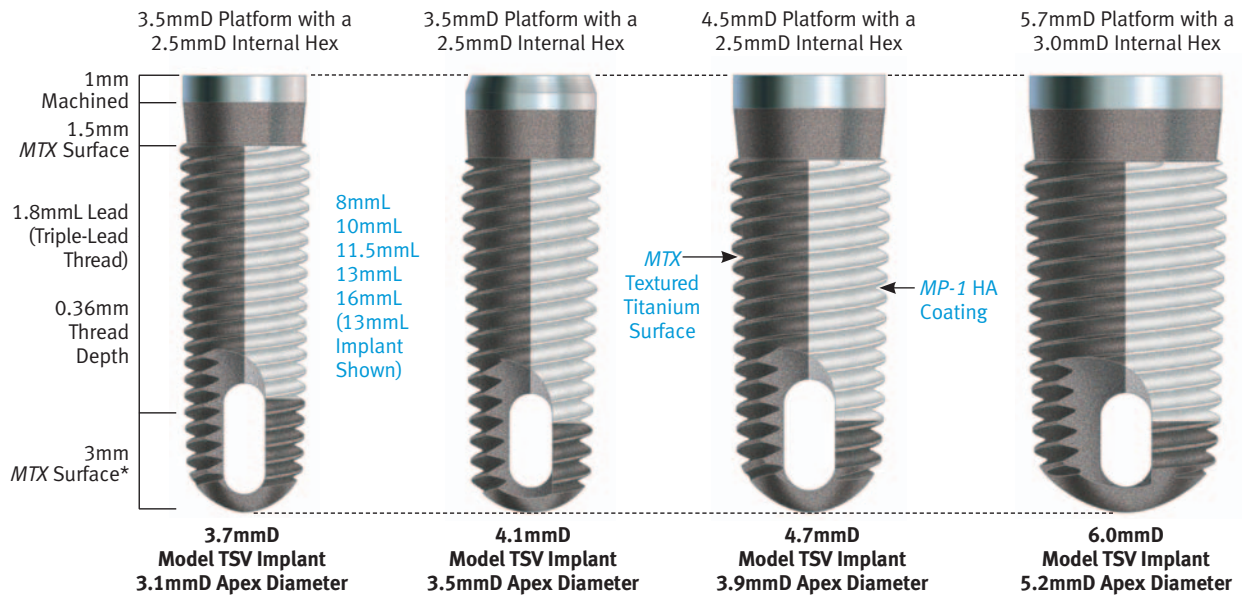
** Transitional space not included in the measurements noted in the schematic.

*** Dimension varies by implant length.

TAPERED SCREW-VENT IMPLANTS

TAPERED SCREW-VENT IMPLANT - 1.0mm MACHINED COLLAR (MODEL TSV)

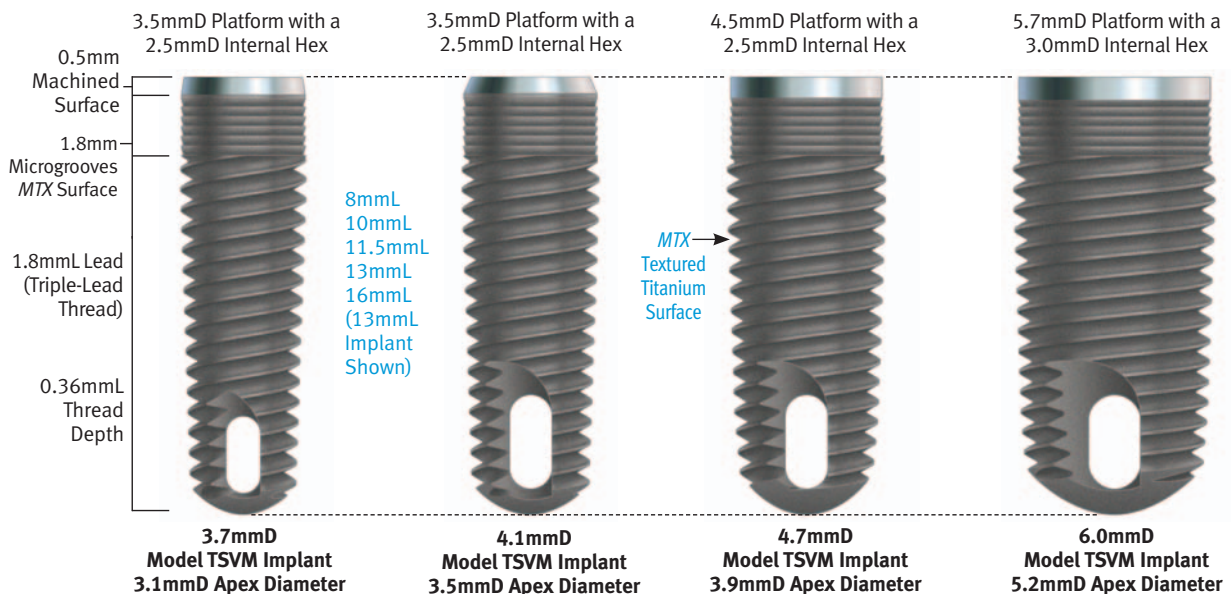
Tapered Screw-Vent Implant features a 1.0mm machined coronal aspect followed by 1.5mm of *MTX* Surface. *Tapered Screw-Vent* Implants taper along the length of the implant originating below the first thread, 3.5mm from the coronal aspect of the implant. In the *MP-1* HA coated implants (Model TSV) the HA coating begins at the first thread, 2.5mm from the coronal aspect of the implant. The degree of taper on the implants varies between 1.0° and 4.0°, depending on their length, to ensure that the apical diameter is consistent among all 5 implant lengths. Therefore the shorter the implant, the greater the degree of taper.



* On HA Coated Implants, the 3mmL apex has an *MTX* surface.

TAPERED SCREW-VENT IMPLANT – 0.5mm MACHINED COLLAR WITH CRESTAL MICROGROOVES (MODEL TSVM)

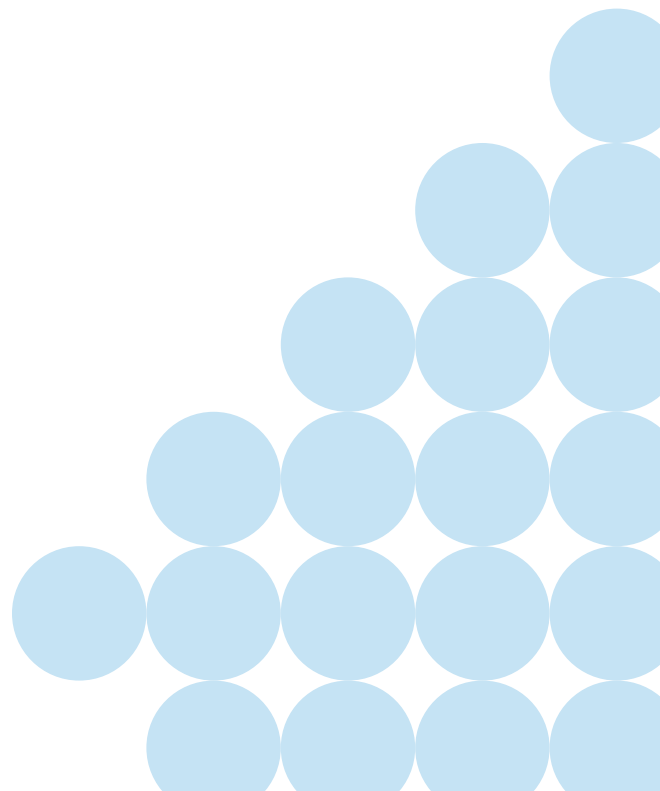
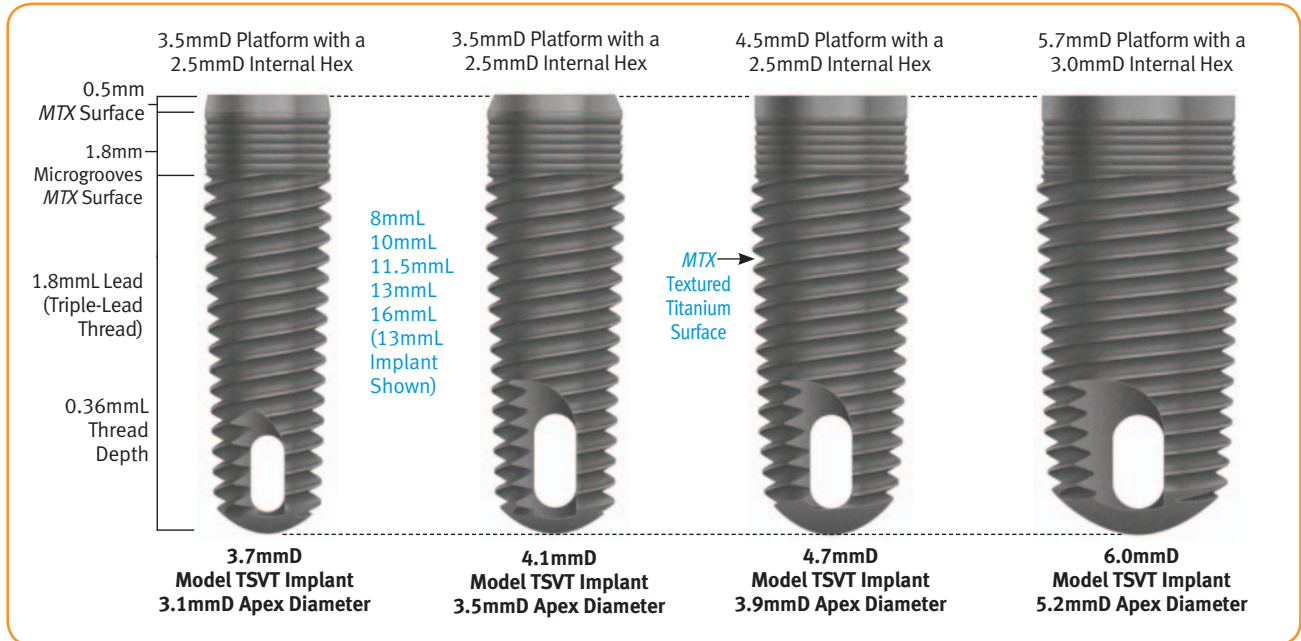
Tapered Screw-Vent Implants are available with additional coronal features. *Tapered Screw-Vent* Implants with 0.5mm machined collar and crestal microgrooves (Model TSVM) maintains 0.5mm of the same smooth machine texture as the traditional *Tapered Screw-Vent* Implant while extending the *MTX* surface texturing to the following 1.8mm of microgrooves. The six microgrooves are circumferential with a depth of 0.06mm and peak-to-peak width of 0.28mm. Triple lead threads begin 2.5mm from the top of the implant and continue to the apex. The degree of body taper varies between 1.0° and 4.0°, depending on their length, to ensure that the apical diameter is consistent among all 5 implant lengths. Therefore the shorter the implant, the greater the degree of taper.



TAPERED SCREW-VENT IMPLANTS

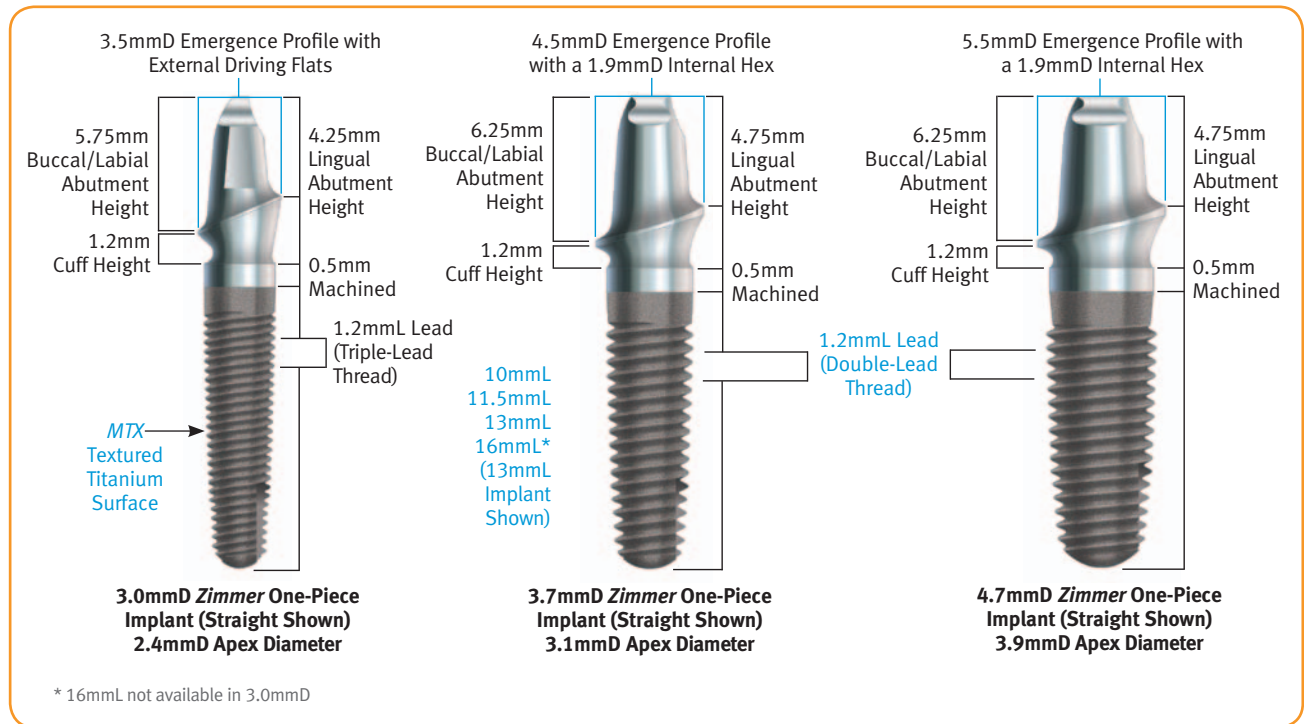
TAPERED SCREW-VENT IMPLANT - FULL TEXTURING AND CRESTAL MICROGROOVES (MODEL TSVT)

Tapered Screw-Vent Implants are available with additional coronal features. *Tapered Screw-Vent* Implants with full texturing and crestal microgrooves (Model TSVT) extends the *MTX* texturing to the coronal aspect, followed by 1.8mm of the *MTX* Surface with microgrooves. The six microgrooves are circumferential with a depth of 0.06mm and peak-to-peak width of 0.28mm. Triple lead threads begin 2.5mm from the top of the implant and continue to the apex. The degree of body taper varies between 1.0° and 4.0°, depending on their length, to ensure that the apical diameter is consistent among all 5 implant lengths. Therefore the shorter the implant, the greater the degree of taper.



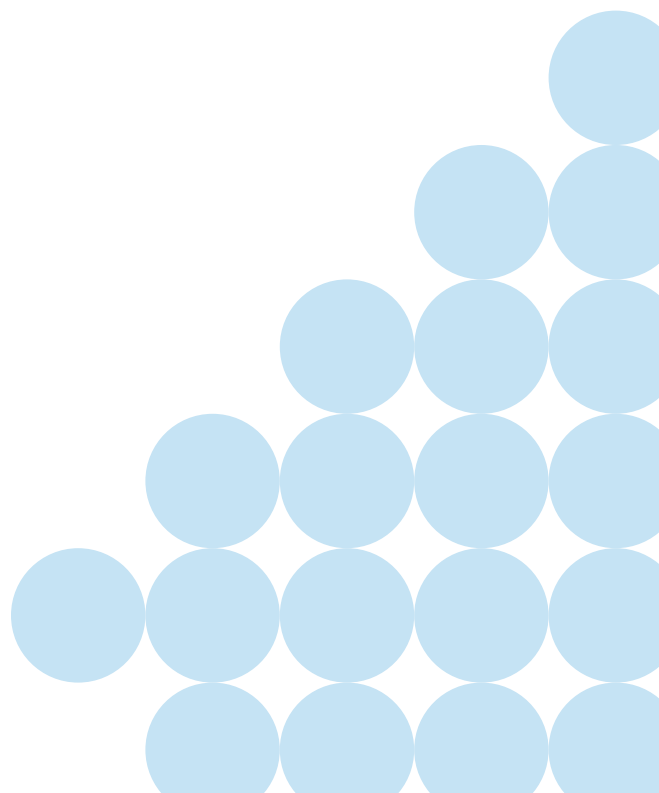
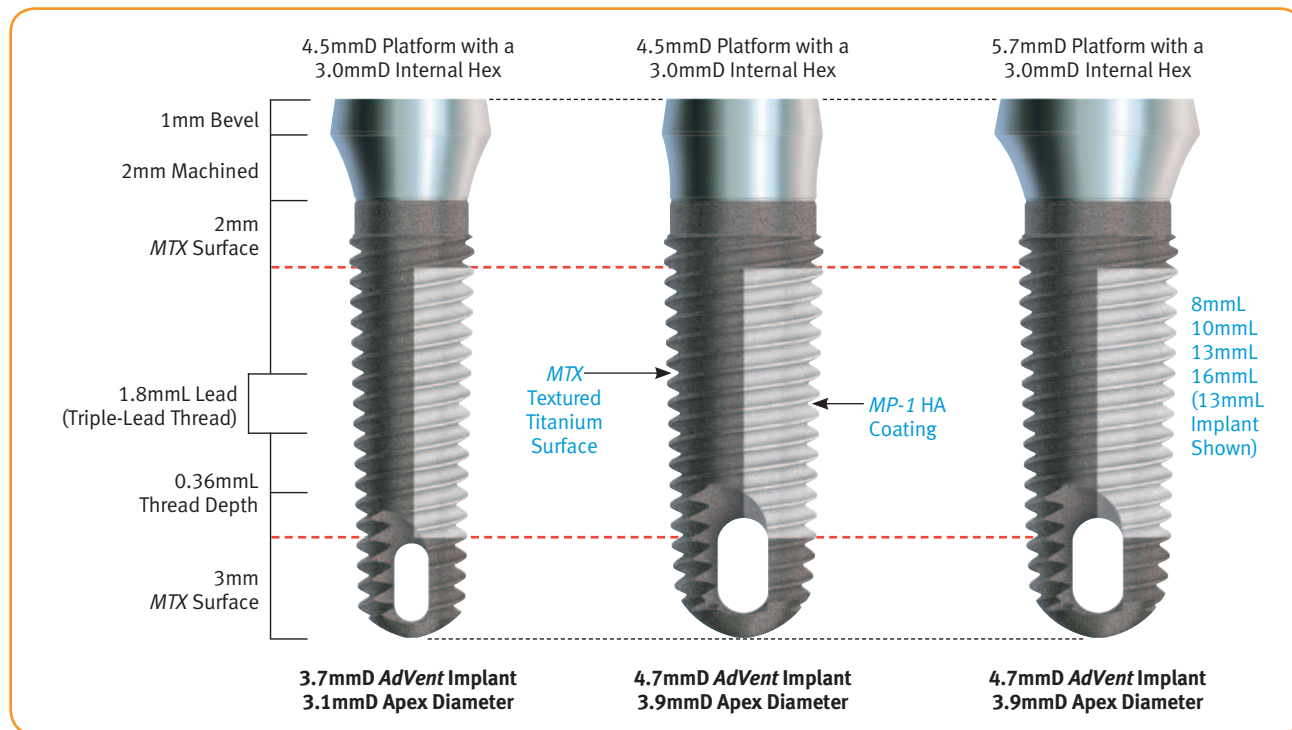
ZIMMER ONE-PIECE IMPLANTS

Similar to the *Tapered Screw-Vent* Implants, the *Zimmer One-Piece Implants* are tapered along the length of the implant beginning 1mm below the start of the threads, or 3.5mm from the end of the machined implant collar. The degree of taper on the implants varies between 1.5° and 2.75°, depending on their length.



ADVENT IMPLANTS

AdVent Implants take into account the tissue-level design concept and therefore have the taper originating 5mm from the coronal aspect of the implant. In the *MP-1* HA coated version of this implant the HA coating begins 2.0mm below the machined implant collar. The degree of taper on the implants varies, depending on their length, to ensure that the apical diameter is consistent among all implant lengths.



MATERIALS

TITANIUM ALLOY

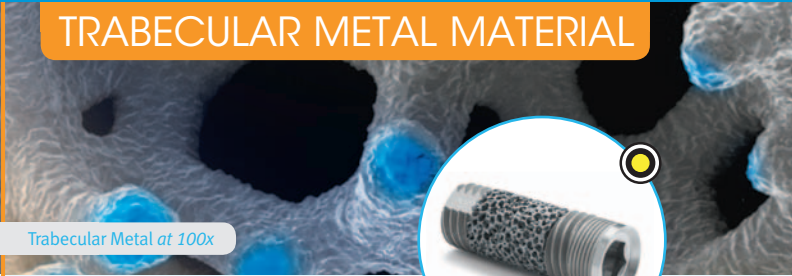


Titanium Alloy 2000x

BIOCOMPATIBILITY AND STRENGTH

- Implants in the *Tapered Screw-Vent* Implant System are made of grade 5 titanium alloy chosen for its biocompatibility¹³ and strength.¹⁴⁻¹⁷
- Minimum tensile and yield strength requirements for this material, set by the American Society for Testing and Materials (ASTM) and the International Organization for Standardization (ISO), are 32% and 59% higher respectively than those of the strongest CP titanium available.¹⁴⁻¹⁷
- Zimmer Dental specifications require that the grade 5 titanium alloy used in *Tapered Screw-Vent* Implants meet or exceed the combined standards of ASTM and ISO.

TRABECULAR METAL MATERIAL



Trabecular Metal at 100x

THE BEST THING NEXT TO BONE.™

- *Trabecular Metal* Material has a three-dimensional cellular architecture with up to 80% porosity.^{3-5,18-21} The structure of *Trabecular Metal* Material is similar to cancellous bone.⁶⁻¹⁸
- *Trabecular Metal* Material is made of tantalum, a highly biocompatible and corrosion-resistant metal²²⁻²⁶ used in various implantable devices for over 60 years.²⁷⁻³¹
- Zimmer has utilized *Trabecular Metal* Material in implantable orthopaedic devices for over a decade.

SURFACES

MTX SURFACE

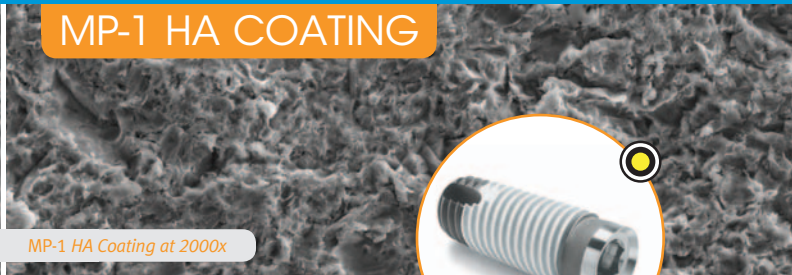


MTX Surface at 2000x

DOCUMENTED MTX SURFACE ADVANTAGES

- High degree of bone-to-implant contact (BIC) and osteoconductive capacity.^{11,13}
- Successful clinical results under conditions of immediate loading.^{14,15}
- Greater than 90% BIC as compared to 42-77% BIC achieved by TPS-coated, sandblasted and acid-etched, oxidized and HA-coated surfaces placed in grafted human sinuses.¹¹

MP-1 HA COATING



MP-1 HA Coating at 2000x

DOCUMENTED MP-1 HA COATING ADVANTAGES

- Up to 96% crystallinity, reducing soluble phases and creating the potential to increase the coating's stability in vivo compared to HA coatings with lower crystallinity.^{16,17}
- High degree of in vivo bone-to-implant contact (BIC)^{11,16} and clinical success rates.^{4,6}
- Higher osteoconductive capacity in native bone after early loading compared to acid-etched surface.¹¹

IMPLANT THREADS AND MICROGROOVE DESIGN

Trabecular Metal and *Tapered Screw-Vent* Implant external threads are based on an industry standard “V” type 60° thread design. Select implants also have six coronal microgrooves with a depth of 0.06mm and a peak-to-peak width of approximately 0.28mm that provide clinical options for crestal bone maintenance.

- *Trabecular Metal* and *Tapered Screw-Vent* Implants have three threads with a uniform 0.35mm thread depth that spiral down the implant adjacent to the other. The distance from one thread to a corresponding point on the adjacent thread (or the pitch) is 0.6mm. The lead or distance the implant will advance into the osteotomy with each complete turn is 1.8mm [Figures 1A, 1B and 2].
- The lead of a triple-lead thread is three times as large as the lead of the standard single-lead thread and therefore these implants can be inserted with one third the number of turns of an implant with a single-lead thread. However, because three adjacent threads run down the implant, the pitch is maintained the same as that of the single-lead thread and the bone contacting surface area of the dense thread pattern is also maintained.
- The triple-lead thread pattern and tapered design of *Tapered Screw-Vent* and *Trabecular Metal* Implants are contributing factors in increasing the primary stability of the implant.

TRABECULAR METAL, TAPERED SCREW-VENT AND ADVENT IMPLANT THREADS

Fig. 1A

Side view of three threads, colored blue, green, or red.

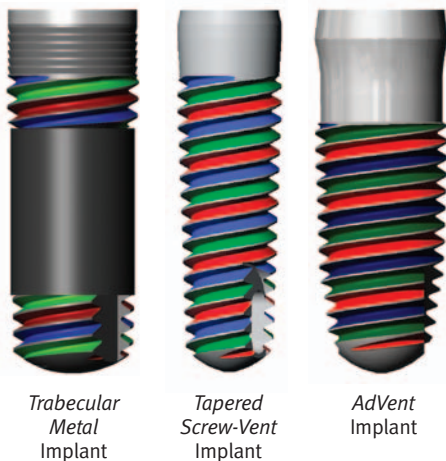


Fig. 1B

Side view of implant with one thread colored to indicate the presence of three threads traversing the length of the threaded portion of the implant.

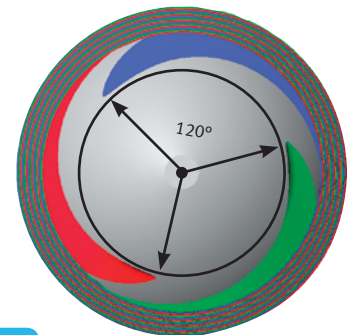
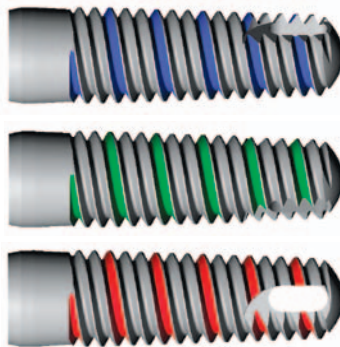


Fig. 2

Apical end of the *Tapered Screw-Vent* Implant and *Trabecular Metal* Implant indicating the start of the three threads 120° from each other.

ZIMMER ONE-PIECE IMPLANT THREADS

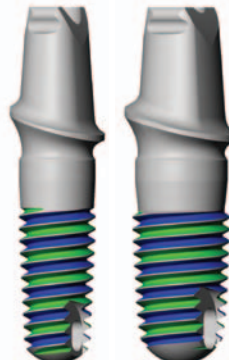
Fig. 3A

3.0mmD *Zimmer* One-Piece Implants have triple-lead threads with a uniform 0.23mm thread depth and 0.4mm thread pitch (peak-to-peak). The lead, or distance the implant will advance into the osteotomy with each complete turn, is 1.2mm.



Fig. 3B

3.7mmD and 4.7mmD *Zimmer* One-Piece Implants have double-lead threads with a 0.6mm thread pitch. Similar to the 3.0mmD Implants, each complete turn will seat the implant 1.2mm.



IMPLANT PLATFORM

Trabecular Metal Implants (Models TMT and TMM)



Implant Diameter	Implant Platform	Connection
4.1mmD	● 3.5mmD	2.5mmD Internal Hexagon
4.7mmD	● 4.5mmD	2.5mmD Internal Hexagon
6.0mmD	● 5.7mmD	3.0mmD Internal Hexagon

Tapered Screw-Vent Implants (Models TSV, TSVM and TSVT)



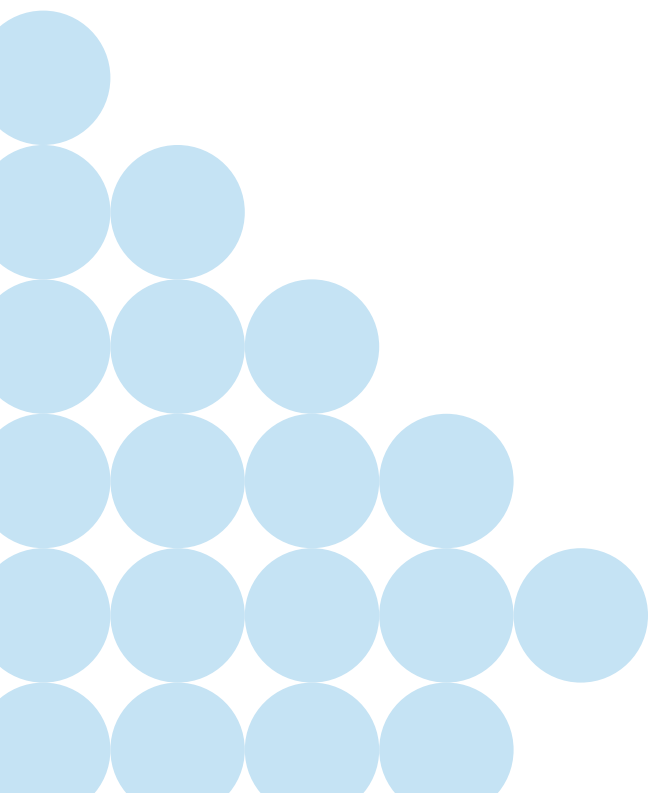
Implant Diameter	Implant Platform	Connection
3.7mmD	● 3.5mmD	2.5mmD Internal Hexagon
4.1mmD	● 3.5mmD	2.5mmD Internal Hexagon
4.7mmD	● 4.5mmD	2.5mmD Internal Hexagon
6.0mmD	● 5.7mmD	3.0mmD Internal Hexagon

AdVent Implants



Implant Diameter	Implant Platform	Connection
3.7mmD	4.5mmD	3.0mmD Internal Hexagon
4.7mmD	4.5mmD	3.0mmD Internal Hexagon
4.7mmD	● 5.7mmD*	3.0mmD Internal Hexagon

*AdVent Implants with a 5.7mmD platform utilize the same prosthetic components as the 6.0mmD *Trabecular Metal* and *Tapered Screw-Vent* Implants.



TRABECULAR METAL & TAPERED SCREW-VENT IMPLANT PLATFORM

The implant platform diameter is measured across the most coronal part of the implant. *Trabecular Metal and Tapered Screw-Vent* Implants have three implant platform diameters and designs:

- 3.5mmD PLATFORM - (Fig. 1A & B)** A 44° internal lead-in bevel extends from the outermost diameter (3.5mmD) of the implant platform into the internal hex of the implant. The internal hex configuration is 2.5mmD flat-to-flat with a depth of 1.5mm. Below the hexagon is a continuation of the inner chamber which leads into the threaded area where the appropriate fixation screw with 1–72 UNF thread is received.

This platform is on the 4.1mmD *Trabecular Metal* Implant and the 3.7mmD and 4.1mmD *Tapered Screw-Vent* Implants.

- 4.5mmD PLATFORM - (Fig. 2A & B)** A 44° internal lead-in bevel extends from the outermost diameter (4.5mmD) of the implant platform into a flattened area or ledge. This ledge extends from the base of the lead-in bevel to the internal hex of the implant. The internal hex configuration is 2.5mmD flat-to-flat with a depth of 1.5mm. Below the hexagon is a continuation of the inner chamber which leads into the threaded area where the appropriate fixation screw with 1–72 UNF thread is received.

This platform is on the 4.7mmD *Trabecular Metal and Tapered Screw-Vent* Implants.

- 5.7mmD PLATFORM - (Fig. 3A & B)** A 44° internal lead-in bevel extends from the outermost diameter (5.7mmD) of the implant platform into a flattened area or ledge. This ledge extends from the base of the lead-in bevel to the internal hex of the implant. The internal hex configuration is 3.0mmD flat-to-flat with a depth of 1.5mm. Below the hexagon is a continuation of the inner chamber which leads into the threaded area where the appropriate fixation screw with 1–72 UNF thread is received.

This platform is on the 6.0mmD *Trabecular Metal and Tapered Screw-Vent* Implants.

3.5mmD PLATFORM

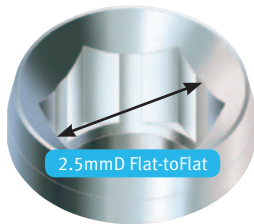


Fig. 1A

3.7mmD Implant and 4.1mmD Implant

4.5mmD PLATFORM

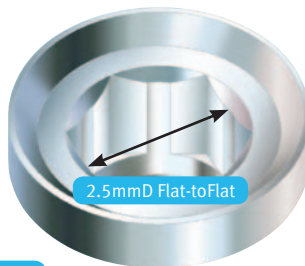


Fig. 2A

4.7mmD Implant

5.7mmD PLATFORM

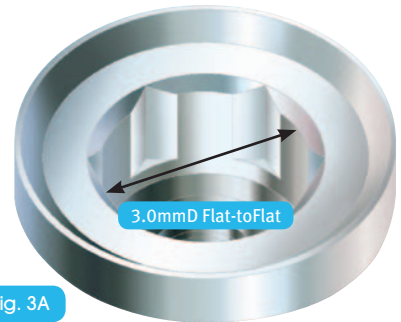


Fig. 3A

6.0mmD Implant

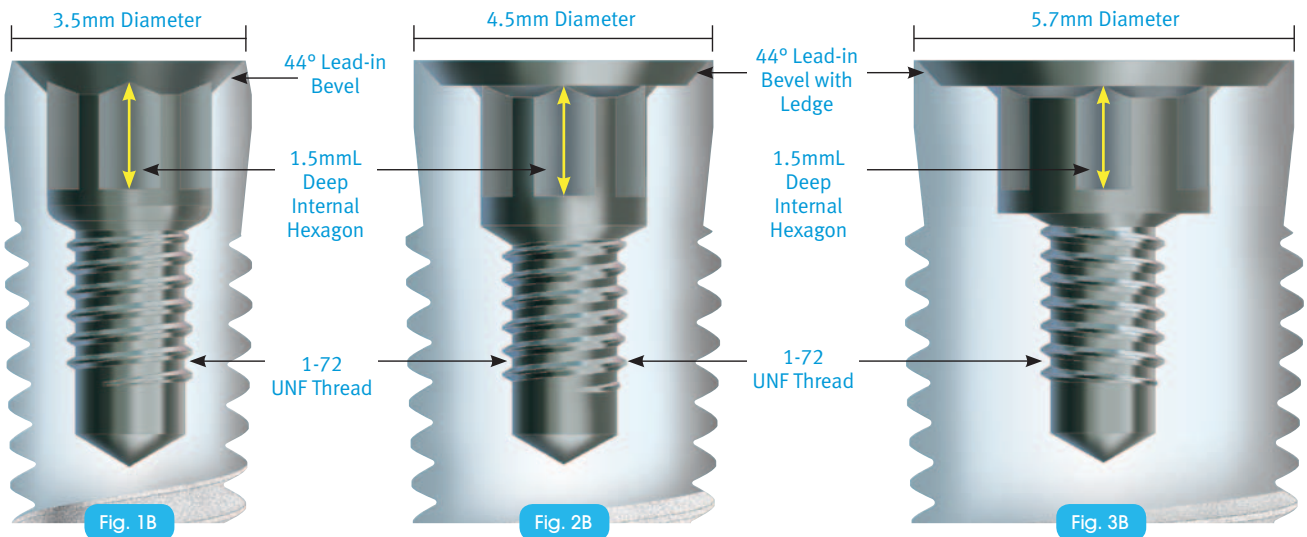


Fig. 1B

Fig. 2B

Fig. 3B

TAPERED SCREW-VENT IMPLANT SHOWN

ADVENT IMPLANT PLATFORM

The *AdVent* Implant System has two implant platform diameters and designs. The implant platform diameter is measured across the most coronal part of the implant and the height of the contour is the widest point of the transmucosal portion of implant (above the undercut of the fluted neck).

- **4.5mmD - (Fig. 1A & B).** A 8° external beveled shoulder tapers up from the height of contour of the implant to the coronal area. Surrounding the opening is a narrow (0.25mmD) ledge which functions as the interface circumference for a majority of the prosthetic components (some components use the height of contour as the prosthetic margin). The height of this bevel extends 1mm above the height of contour (4.8mmD). From the edge of the opening, a 44° tapered internal beveled wall leads into a 3.0mmD flat-to-flat hexagon which is 1.25mm deep. Below the hexagon is a continuation of the inner chamber which leads into the threaded area where the appropriate fixation screw with 1-72 UNF thread is received.

This platform is on all lengths of the [AV] and [AVW] series of implants.

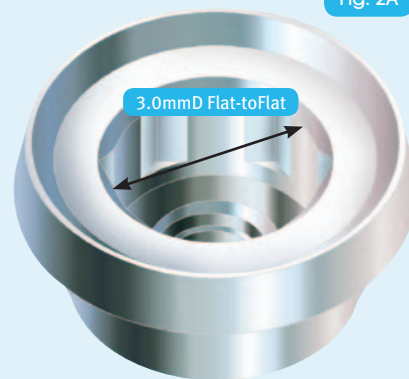
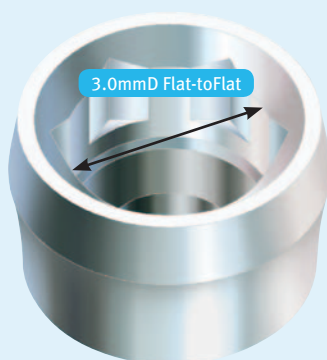
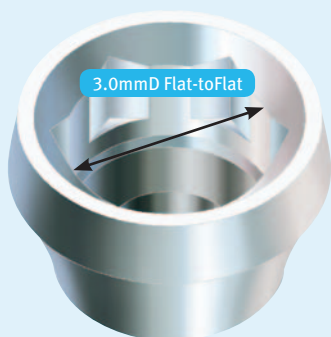
- **5.7mmD - (Fig. 2A & B).** A 11° external beveled shoulder tapers up from the height of contour of the implant to the coronal area which has a 5.7mmD prosthetic platform. The height of this bevel extends 1mm above the height of contour (6.1mmD). From the edge of the opening, a 44° tapered internal beveled wall leads into a flattened area or ledge that extends to a 3.0mmD flat-to-flat hexagon which is 1.5mm deep. Below the hexagon is a continuation of the inner chamber which leads into the threaded area where the appropriate fixation screw with 1-72 UNF thread is received. **This implant utilizes the same prosthetic components used with the 6.0mmD Trabecular Metal and Tapered Screw-Vent Implant.**

4.5mmD PLATFORM

5.7mmD PLATFORM

Fig. 1A

Fig. 2A



3.7mmD Implant

4.7mmD Implant

4.7mmD Implant

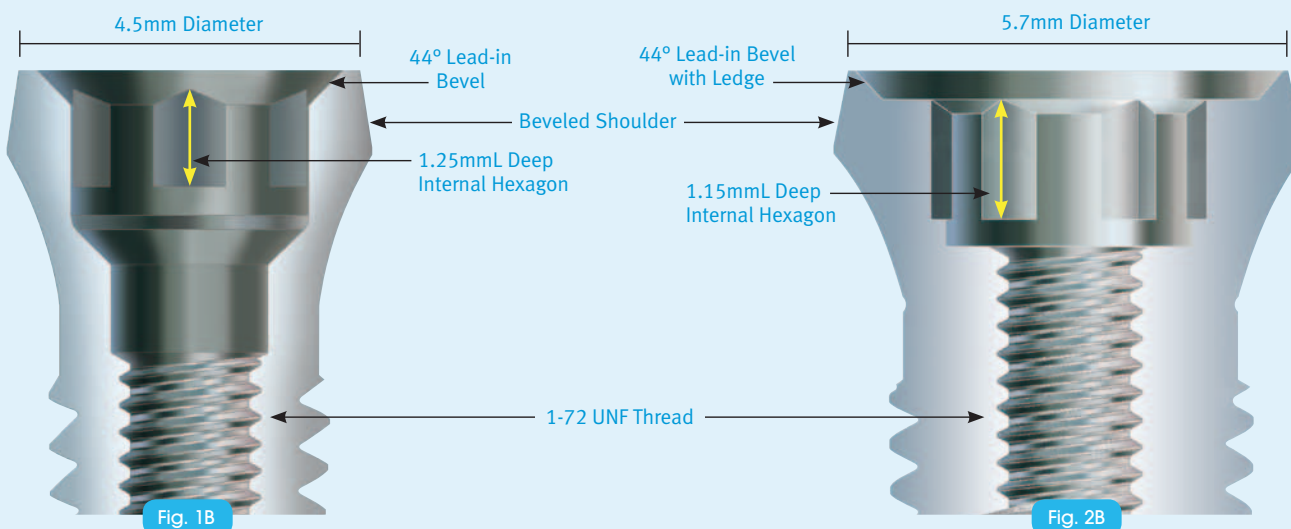


Fig. 1B

Fig. 2B

ZIMMER ONE-PIECE IMPLANT PLATFORM

The *Zimmer One-Piece Implant* is an endosteal, root-form dental implant in which the implant and abutment are manufactured together as one unified component. The implant portion is tapered with either double- or triple-lead threads, depending on the cervical diameter of the implant body, and is designed with the same proportions and features as the *Tapered Screw-Vent Implant*. The abutment portion has pre-contoured margins in straight or angled emergence profiles, like those of the *Hex-Lock® Contour Abutment* design [Figure 1].

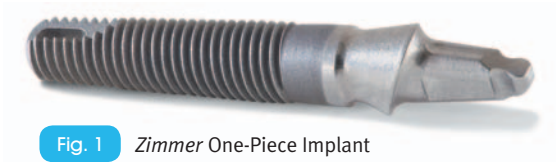


Fig. 1 Zimmer One-Piece Implant

Due to the integrated abutment, there are several additional dimensions to consider when utilizing a *Zimmer One-Piece Implant*:

ABUTMENT EMERGENCE PROFILE The emergence profile is measured across the widest buccolingual abutment diameter. The 3.0mmD *Zimmer One-Piece Implant* has a 3.5mmD prosthetic emergence profile, the 3.7mmD implant has a 4.5mmD prosthetic emergence profile and the 4.7mmD implant has a 5.5mmD prosthetic emergence profile [Tables A & B].

Table A

Zimmer One-Piece Implants – Straight	
Implant Diameter	Abutment Emergence Profile
3.0mmD	3.5mmD
3.7mmD	4.5mmD
4.7mmD	5.5mmD

Table B

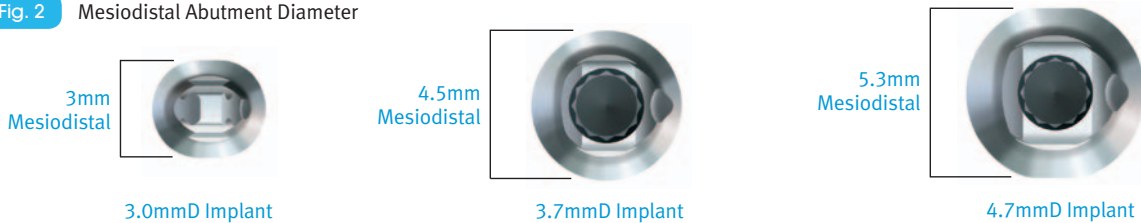
Zimmer One-Piece Implants – 17° Angled		
Implant Diameter	Abutment Emergence Profile	Cone Rotation Diameter
3.0mmD	3.5mmD	4.3mmD*
3.7mmD	4.5mmD	4.5mmD
4.7mmD	5.5mmD	5.5mmD

* Rotation diameter of the 3.0mmD implant is the diameter of the external driver.

ANGLED PROSTHETIC CONE ROTATION DIAMETER The 3.0mm and 3.7mm 17° Angled *Zimmer One-Piece Implants* have a cone rotation diameter only slightly larger than the prosthetic emergence profile, enabling placement of the angled option in sites where space is limited. The 4.7mm 17° Angled *Zimmer One-Piece Implant* has a cone rotation equivalent to its prosthetic emergence profile [Table B].

MESIODISTAL ABUTMENT DIAMETER The mesiodistal abutment diameter is 3.0mm for the 3.0mmD *Zimmer One-Piece Implant*, 4.5mm for the 3.7mmD implant and 5.3mm for the 4.7mmD implant [Figure 2].

Fig. 2 Mesiodistal Abutment Diameter



3mm Mesiodistal



3.0mmD Implant

4.5mm Mesiodistal



3.7mmD Implant

5.3mm Mesiodistal



4.7mmD Implant

PLATFORM PLUS TECHNOLOGY

Zimmer's *Tapered Screw-Vent* Implant System features *Platform Plus* Technology that creates favorable conditions for bone-level maintenance.^{11,32}

Zimmer Dental's internal anti-rotational interface has been an industry standard since its introduction in 1986. This internal hex design continued to evolve and improve with the introduction of friction-fit technology, a breakthrough feature that creates a virtual "cold weld" between the implant and abutment.

- **1.5mm deep internal hex** - shields the abutment screw from excess loading, distributing occlusal forces deep into the implant¹⁴ [Figure A].
- **Lead-in bevel** - designed to reduce horizontal stresses better than flat "butt-joint" connection^{14,15} [Figure B].
- **Friction-fit connection** - designed to eliminate abutment micromovement associated with screw-loosening¹⁴ [Figure C].

Platform Plus Technology features a friction-fit connection formed when the male abutment hexagon mates with the female hexagon of the implant, and a retention screw threaded through the abutment body and into the implant is tightened to a recommended 30 Ncm of applied torque. To reduce potential rotational misfit, abutment vibration and tipping generally associated with abutment screw loosening in dental literature, the male hexagon is designed with a one-degree taper. This features creates an interference-fit with the implant which is designed to eliminate abutment micromovement when the retaining screw is tightened as recommended.

Fig. A

Proprietary friction-fit connection with lead in bevel and virtual cold weld.

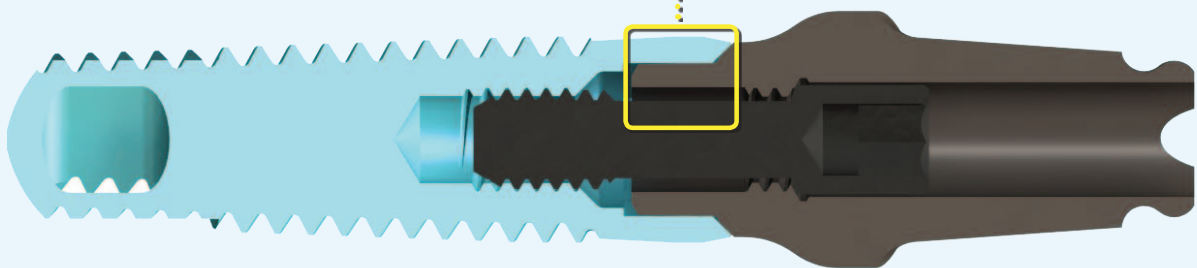
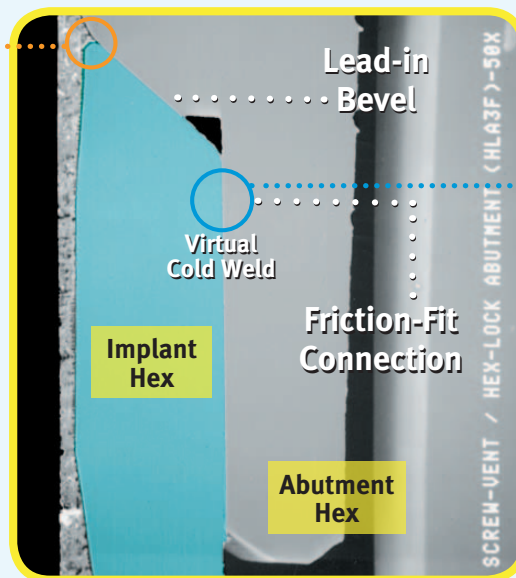
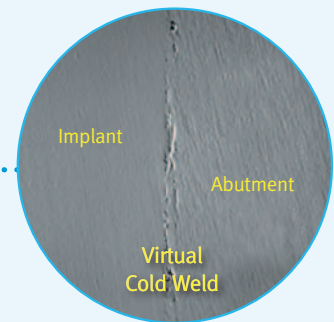
Fig. B

Higher magnification of unique beveled interface and full interface seal.

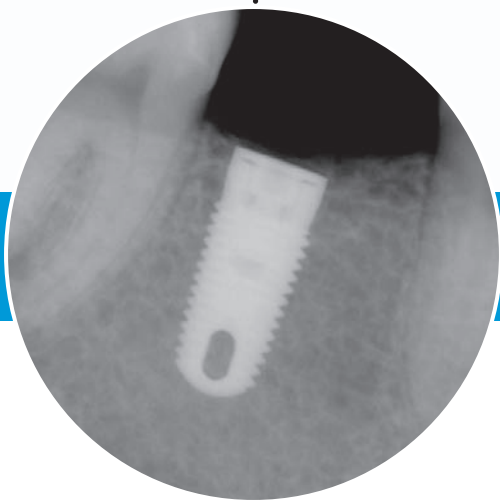


Fig. C

Higher magnification of the virtual cold weld between the abutment and implant.



IMPLANT SELECTION GUIDELINES



IMPLANT CHART

BONE-LEVEL IMPLANTS



	TRABECULAR METAL IMPLANTS	TAPERED SCREW-VENT IMPLANTS
Diameter	4.1, 4.7, 6.0mm	3.7, 4.1, 4.7, 6.0mm
Length	10, 11.5, 13mm	8, 10, 11.5, 13, 16mm
Platform Diameter	3.5, 4.5, 5.7mm	3.5, 4.5, 5.7mm
Materials	Trabecular Metal Material & Titanium Alloy	Titanium Alloy
Coronal Features	0.5mm MTX Surface 0.5mm Machined with Microgrooves	1mm Machined 0.5mm MTX Surface with Microgrooves 0.5mm Machined with Microgrooves
Upper Surface	MTX Surface	MTX Surface
Middle Surface	Trabecular Metal Material	MTX or MP-1 HA Surface
Lower Surface	MTX Surface	MTX Surface
Body Design	Tapered	Tapered
Threads	Triple-Lead	Triple-Lead
Connections	Internal Hexagon 2.5mmD, 3.0mmD	Internal Hexagon 2.5mmD, 3.0mmD
Surgical Kit	Zimmer Instrument Kit System	Zimmer Instrument Kit System
Zimmer Guided Surgery Instrumentation (osteotomy creation)	4.1, 4.7mmD	3.7, 4.1, 4.7mmD

ONE-PIECE IMPLANTS



TISSUE-LEVEL IMPLANTS



ZIMMER ONE-PIECE IMPLANTS

ADVENT IMPLANTS

Diameter	3.0, 3.7, 4.7mm	3.7, 4.7mm
Length	10, 11.5, 13, 16mm	8, 10, 13, 16mm
Platform Diameter	N/A	4.5, 5.7mm
Materials	Titanium Alloy	Titanium Alloy
Coronal Features	0.5mm Machined Contour Abutment	1mm Machined Bevel + 2mm Machined Transgingival Collar
Upper Surface	MTX Surface	MTX Surface
Middle Surface	MTX Surface	MTX or MP-1 HA Surface
Lower Surface	MTX Surface	MTX Surface
Body Design	Tapered	Tapered
Threads	Triple-Lead - 3.0mmD; Double-Lead - 3.7mm, 4.7mmD	Triple-Lead
Connections	N/A	Internal Hexagon
Surgical Kit	Zimmer Instrument Kit System	Zimmer Instrument Kit System
Zimmer Guided Surgery Instrumentation (osteotomy creation)	Yes, up to 4.7mmD	Yes, up to 4.7mmD

ANATOMICAL CRITERIA

**“WHAT IS THE BEST IMPLANT FOR THE PROPOSED RESTORATION?”
THIS QUESTION ALWAYS ARISES DURING THE PROCESS OF CASE DIAGNOSIS AND TREATMENT PLANNING.**

The design, quantity, diameter, and length of implants to be placed will depend on the type of restoration planned (implant or tissue supported; cement- or screw-retained) as well as the following anatomical criteria:

- Quality and quantity of available bone.
- A distance of 3.0mm between implants and a distance of 2mm between implants and adjacent teeth is recommended for optimal preservation of interproximal marginal bone levels and papillary soft tissue height [Figure A].
- Overdenture is to be implant supported or tissue supported/implant retained.
- Cement- or screw-retained restoration.

Fig. A

MINIMUM SURGICAL SPACE BETWEEN IMPLANTS

Allow 3.0mm mesiodistal space between implants.



- Mesial and/or distal boundaries.
 - a) Mesial and distal borders of surrounding coronal contours. Example: In Figure B, the 3.7mmD implant platform is preferable to the 4.7mmD due to mesiodistal constraints. At least 1mm on either side of the platform is the minimum requirement for restorative contours.
 - b) Convergent or divergent roots. Tapered implants allow for larger diameter in this area [Figure C].
 - c) Mental foramina.

Fig. B

PROSTHETIC REQUIREMENT OF IMPLANT PLACEMENT

In this case, the 3.0mm implant and 3.7mm implant is preferable to allow 1mm on either side of the platform.

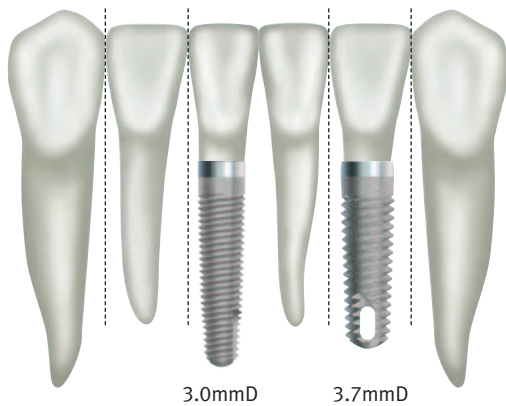
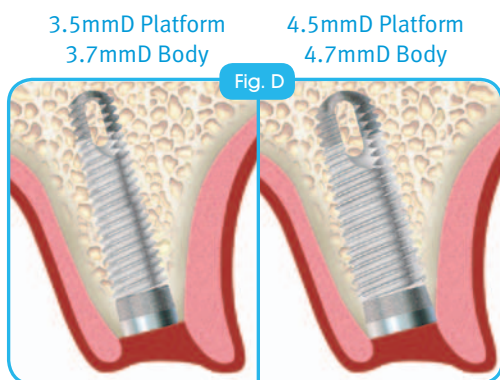


Fig. C

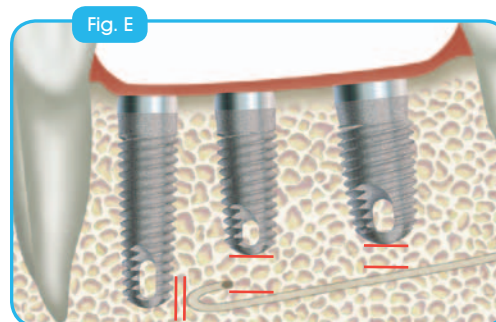
Convergent roots advocate use of tapered implants.



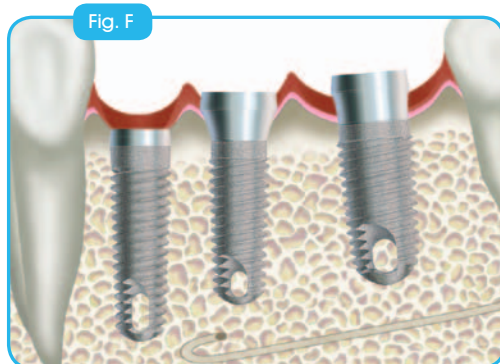
- Buccal and/or lingual boundaries.
 - a) Buccal and/or lingual restoration contours. Minimum requirement for restorative contours is 1mm on either side of the platform diameter.
 - b) Restorations require space for sub-structures and substantial veneering materials (i.e., denture).
 - c) Buccal and/or lingual osseous depressions require the use of narrow or tapered implants [Figures D].
 - d) Width of the crestal bone requires the use of implants that have a neck diameter which allows for a minimum of 1-1.5mmD of bone on buccal and lingual borders [Figure D].
 - e) Available bone to allow placement such that the occlusal force is axial through the center of the implant body.
- Anatomical vertical limitations.
 - a) Maintaining a distance of 1.0mm to 2.0mm between the maximum osteotomy depth and the superior boundary of the mandibular canal is recommended to avoid impingement of the neurovascular bundle [Figure E].



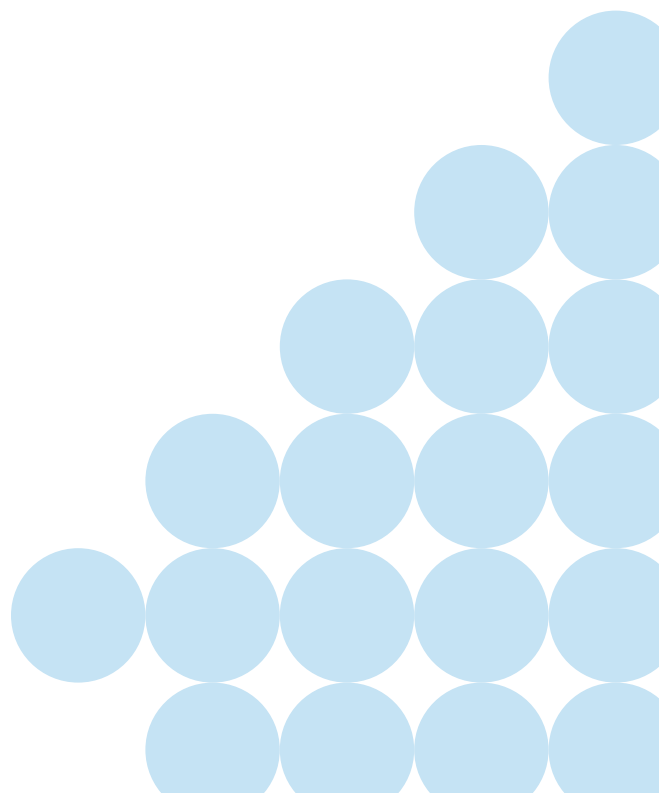
Buccolingual bone requirements (1-1.5mmD) in some cases advocate use of a narrower implant.



Allow spacing of at least 2mm above the mandibular canal (Illustration not to scale).



Esthetic requirements can help guide the decision to use bone- or tissue-level implants.





ZIMMER INSTRUMENT KIT SYSTEM









SYSTEM OVERVIEW

The *Zimmer Instrument Kit System* features easily customizable instrument configurations for placement of *Trabecular Metal, Tapered Screw-Vent, Zimmer One-Piece* and *AdVent Implants*.

From complete set-ups that include all instrumentation, to optional modules that easily snap into the main *Tapered Screw-Vent Surgical Kit*, the *Zimmer Instrument Kit System* allows flexibility to conveniently adapt one surgical kit to support both traditional and more advanced techniques. Intuitive instrument organization and color-coding make the surgical sequence easy to learn and follow, streamlining the surgical procedures.

ZIMMER INSTRUMENT KIT SYSTEM OPTIONS

The *Zimmer Instrument Kit System* is comprised of the following surgical kits and modules in support of Traditional and Guided surgery techniques. Some elements can be used as stand-alone surgical accessories or in conjunction with the kits.

Zimmer Instrument Kit System		<i>Tapered Screw-Vent Surgical Kit</i>	<i>Zimmer Drill Stop Kit</i>	<i>Zimmer Drill Module with Driva™ EG Drills</i>	<i>Zimmer Tube Adapter Kit</i>	<i>Zimmer One-Piece Upgrade Module</i>	<i>Zimmer One-Piece Surgical Kit (stand-alone)</i>
Procedure Type and Implant System							
Traditional Surgery	<i>Trabecular Metal, Tapered Screw-Vent and AdVent Implants</i>	✓	✓				
	<i>Zimmer One-Piece Implants</i>	✓	✓			✓	✓*
Guided Surgery	<i>Trabecular Metal, Tapered Screw-Vent and AdVent Implants</i>	✓		✓	✓		
	<i>Zimmer One-Piece Implants</i>	✓		✓**	✓	✓**	✓*

* The stand-alone *Zimmer One-Piece Surgical Kit* is an alternative to the *Tapered Screw-Vent Surgical Kit* with *Zimmer One-Piece Upgrade*.

**When placing *Zimmer One-Piece Implants* in a guided surgical procedure, the *Zimmer Drill Module* occupies the space for the *Zimmer One-Piece Upgrade* in the *Tapered Screw-Vent Surgical Kit*. In this case, the stand-alone *Zimmer One-Piece Surgical Kit* may be utilized or a second *Tapered Screw-Vent Surgical Kit* with *Zimmer One-Piece Upgrade* module is required.



TAPERED SCREW-VENT STAGING BLOCK

The *Tapered Screw-Vent Staging Block*, provided with each main kit configuration and available separately, can be used for staging of instruments while the Block graphics assist in verification of the implant lengths and drilling depth.

GENERAL SURGICAL INSTRUCTIONS

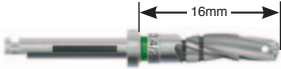

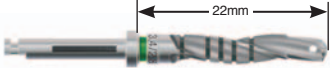
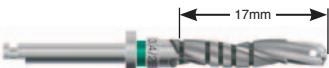
All instruments must be cleaned and sterilized prior to use following directions in the Instructions for Use. Fully assembled kits and empty trays are provided non-sterile. Some instruments purchased individually are provided sterile, as noted on the product label. Drills have been marked with sizes and selected drills have been color-coded for ease of identification. Size marking and color-coding should be used to select proper drill for each surgical procedure.

Surgical instruments are susceptible to damage and wear and should be inspected before use. The number of

uses per drill will vary and depends on a variety of factors including bone density encountered, proper handling and cleaning. Over time, repeat sterilizations may affect cutting efficiency and color appearance. Cutting edges should present a continuous edge and appear sharp. Check the latch-lock shank for wear to ensure the connection is not damaged. If inspection reveals signs of wear, damage, or unrecognizable color identification, replace the drill accordingly.

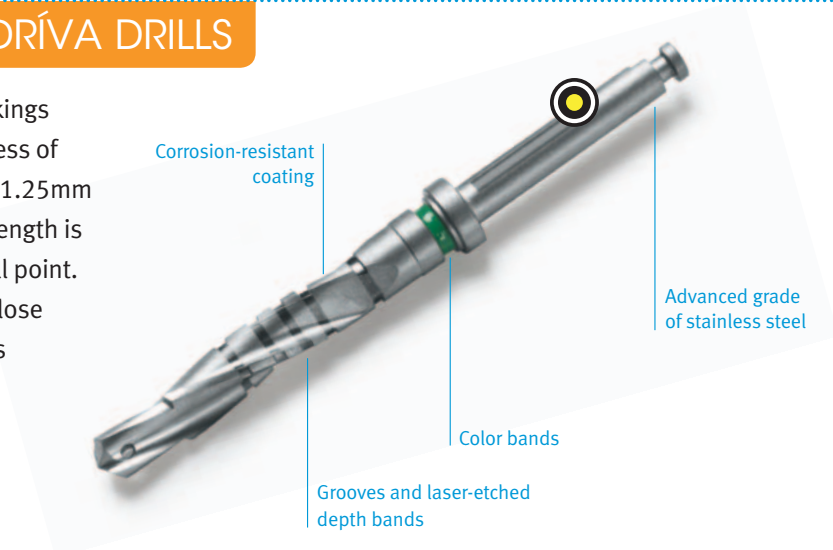
Note: For complete instructions, refer to the Instructions for Use for each product.

NEW DRILL NOMENCLATURE – NEW MEASURING TECHNIQUE/NOMENCLATURE FOR DRIVA DRILLS USED IN THE PLACEMENT OF TRABECULAR METAL, TAPERED SCREW-VENT, ZIMMER ONE-PIECE AND ADVENT IMPLANTS.

NEW MEASURING TECHNIQUE LABEL DESCRIPTION	PREVIOUS MEASURING TECHNIQUE LABEL DESCRIPTION
	
<p>The new measurement indicates the distance from the tip of the drill to the bottom of the flange. This measures 16mm for a short drill.</p>	<p>The previous measurement indicated the distance from the tip of the drill to the last laser mark. This measured 11mm for a short drill.</p>
	
<p>The new measurement indicates the distance from the tip of the drill to the bottom of the flange. This measures 22mm for a long drill.</p>	<p>The previous measurement indicated the distance from the tip of the drill to the last laser mark. This measured 17mm for a long drill.</p>

HIGH-PERFORMANCE DRIVA DRILLS

Note: The top of the laser/score line markings (0.5mm in height) on the drills are in excess of the length of the implant to be placed by 1.25mm (8mmL is actually 9.25mm). This added length is to accommodate for the design of the drill point. The 2.3mmD Drill is the only drill that is close to the actual implant length (i.e., 8mmL is actually 8.25mmL).



CLEANING & STERILIZATION GUIDELINES

Note: For detailed cleaning and sterilization instructions, refer to the Instructions for Use for each product.

CLEANING

Instruments in the *Zimmer Instrument Kit System*:

Disassemble two-piece components. Rinse instruments in cool to lukewarm water for **2.5 minutes**. For drills, use the Zimmer cleaning wire to remove any debris from the irrigation channel. Using a 25 gauge needle flush the drill lumen with water to remove any remaining debris. Sonicate the instruments for **10 minutes** in an ultrasonic cleaner with a pH-neutral enzymatic detergent diluted with tap water per the manufacturer's instructions. Rinse the instruments with tap water for **3 minutes**. Inspect the instruments for signs of wear, damage, or unrecognizable color identification and replace the instruments accordingly.

Surgical Trays: *Tapered Screw-Vent Surgical Kit, Zimmer One-Piece Surgical Kit, Staging Block (excluding Zimmer Drill Stop Kit and Zimmer Tube Adapter Kit)*:

Remove all parts and insert from the tray. Clean parts per the above instructions. Thoroughly rinse the kits under running tap water to remove all visible soil. Use a soft bristle brush to clean the kits until all visible soil is removed. A syringe or pipe cleaner may be used to aid in the rinsing. Assure that all hard to reach areas are accessed. After the rinsing, prepare the enzymatic detergent following the manufacturer's specifications. Fully immerse the kit in the prepared detergent and allow the kit to soak in the detergent for a minimum of **1 minute**. Following the soak

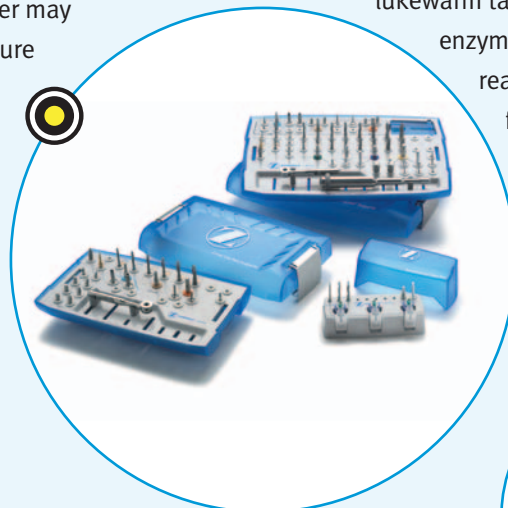
use a damp cloth and/or a soft bristle brush to wipe and remove any excess debris/soil from each component. Rinse the kits with lukewarm tap water to eliminate all residual enzymes and detergent thoroughly for a minimum of **3 minutes**. Dry the components. Reassemble the contents of the kit and follow the guidelines for sterilization.

Note: This procedure should be performed after an instrument used during a surgery comes into contact with the surgical tray or prosthetic tray.

Zimmer Drill Stop Kit and Zimmer Tube Adapter Kit

Remove all components from the kit. Clean parts per the above instructions. Thoroughly rinse the kit under running tap water to remove all visible soil. Use a soft bristle brush to clean the kit until all visible soil is removed. A syringe or pipe cleaner may be used to aid in the rinsing. Assure that all hard to reach areas are accessed. After the rinsing, prepare the enzymatic detergent following the manufacturer's specifications. Fully immerse the kit in the prepared detergent and allow the kit to soak in the detergent for a minimum of **5 minutes**. Following the soak, use a damp cloth and/or a soft bristle brush to wipe and remove any excess debris/soil from each component. Rinse the kits with lukewarm tap water to eliminate all residual enzymes and detergent. Dry the components, reassemble the contents of the kit and follow the guidelines for sterilization.

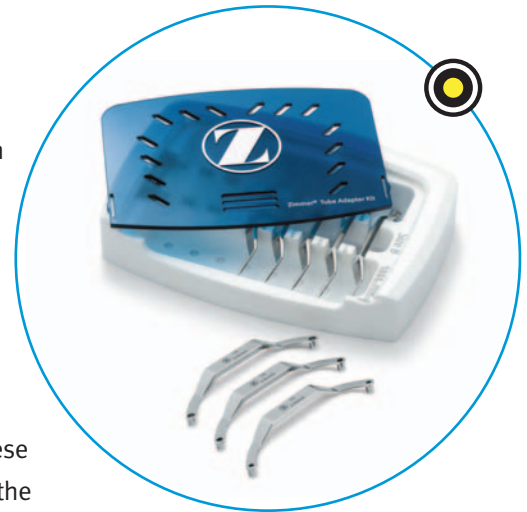
Note: This procedure should be performed after an instrument used during a surgery comes into contact with the kit.



STERILIZATION

General Sterilization Guidelines for *Zimmer Instrument Kit System*

Individual parts should be placed in appropriate autoclave or dry heat pouch prior to sterilization. Dry heat sterilization is not recommended for Zimmer surgical trays. When sterilizing parts within a kit, parts should be placed in appropriate locations and kit should be wrapped in sterilization wrap. The following sterilization parameters (method, time and temperature) are required to achieve a 10⁻⁶ sterility assurance level (SAL). Local or national specifications should be followed where steam sterilization requirements are stricter or more conservative than those listed in the table. Exceeding these sterilization parameters may result in damage to plastic components. Verify the calibration of your unit to ensure recommended temperatures are not being exceeded.



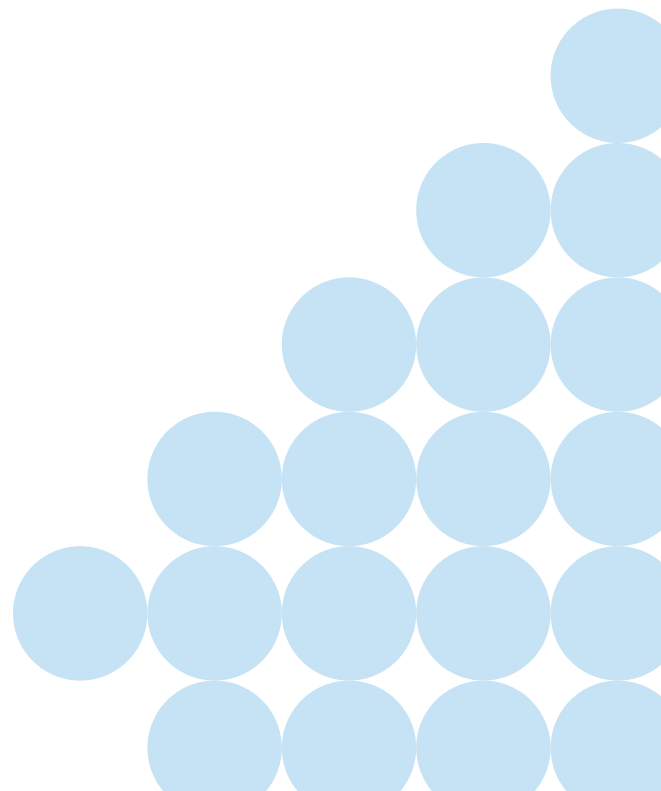
Note: To ensure autoclave is performing effectively, periodic use of biologic indicators should be considered. Chemclave is NOT recommended for any Zimmer components. Dry heat sterilization is NOT recommended for any plastic Zimmer components.

RECOMMENDED STERILIZATION PARAMETERS FOR ZIMMER INSTRUMENT KIT SYSTEM

Cycle Type	Temperature	Exposure Time	Dry Time
^{1,2} Pre-vacuum (steam)	132°C / 270°F	3 minutes	30 minutes
² Pre-vacuum (steam)	134°C / 273°F	18 minutes	30 minutes
¹ Gravity (steam)	121°C / 250°F	80 minutes	30 minutes

¹ Minimum validated sterilization time and temperature required to achieve a 10⁻⁶ sterility assurance level (SAL).

² Local or national specifications should be followed where steam sterilization requirements are stricter or more conservative than those listed in this table.



COLOR REFERENCE CHARTS

IMPLANT COLOR REFERENCE CHART:
TRABECULAR METAL AND TAPERED SCREW-VENT IMPLANTS

IMPLANT DIAMETER	3.7mmD	4.1mmD	4.7mmD	6.0mmD
Surgical sequence color bar*				
Drill band color for dense bone protocol				
Implant cap color and restorative platform	 3.5mmD	 3.5mmD	 4.5mmD	 5.7mmD
Tapered Screw-Vent Vial cap label				
Trabecular Metal Vial cap label Note: Yellow vial of <i>Trabecular Metal</i> Implant does not correspond to 5.7mmD Platform				

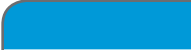















Note: The surgical sequence for the 4.1mmD *Tapered Screw-Vent* Implant is color-coded white on the surgical kit surface. The implant vial cap color remains green as an indication of the 3.5mm prosthetic platform.

ZIMMER ONE-PIECE IMPLANTS

IMPLANT DIAMETER	3.0mmD	3.7mmD	4.7mmD
Surgical sequence color bar*			
Drill band color for dense bone protocol			
Implant cap color and abutment emergence profile	 3.5mmD	 4.5mmD	 5.5mmD
Driver band color			
Tap band color			
Vial cap label			

* Denotes drilling sequence indicated on surgical tray surface .

INSTRUMENT COLOR REFERENCE CHART: TRABECULAR METAL, TAPERED SCREW-VENT AND ZIMMER ONE-PIECE IMPLANTS

BAND COLOR	INSTRUMENT DESCRIPTION
	Driver for 3.0mmD <i>Zimmer</i> One-Piece Implant, Straight
	Driver for 3.0mmD <i>Zimmer</i> One-Piece Implant, 17°
	Driver, 19mmL, for 3.7mmD and 4.7mmD <i>Zimmer</i> One-Piece Implant, Straight and 17°
	Driver, 24mmL, for 3.7mmD and 4.7mmD <i>Zimmer</i> One-Piece Implant, Straight and 17°
	<i>Dríva</i> Step Drill, Instrument Kit System, 2.8/2.4mmD*
	<i>Dríva</i> Step Drill, Instrument Kit System, 3.4/2.8mmD
	<i>Dríva</i> Step Drill, Instrument Kit System, 3.4/2.8mmD
	<i>Dríva</i> Step Drill, Instrument Kit System, 3.8/3.4mmD
	<i>Dríva</i> Step Drill, Instrument Kit System, 3.8/3.4mmD
	<i>Dríva</i> Step Drill, Instrument Kit System, 4.4/3.8mmD
	<i>Dríva</i> Step Drill, Instrument Kit System, 4.4/3.8mmD
	<i>Dríva</i> Step Drill, Instrument Kit System, 5.7/5.1mmD
	<i>Dríva</i> Step Drill, Instrument Kit System, 5.7/5.1mmD
	Cortical Bone Tap for 3.0mmD <i>Zimmer</i> One-Piece Implant*
	Cortical Bone Tap for 3.7mmD <i>Zimmer</i> One-Piece Implant*
	Cortical Bone Tap for 4.7mmD <i>Zimmer</i> One-Piece Implant*

*Denotes use with the *Zimmer* One-Piece Implant.

DRILLING SEQUENCE GUIDELINES

Soft bone protocol: follow solid color bars on the surgical tray surface until the segmented color bar. The segmented color bar indicates the final drill for soft bone protocol.

Dense bone protocol: follow solid color bars only. The last solid bar in the sequence represents the final drill for dense bone.

Note: 3.0mm and 3.7mm *Zimmer* One-Piece Implants have a dense bone protocol only.



TAPERED SCREW-VENT SURGICAL KIT

- | | | | | | | | | | | |
|--|--|---|---|---|---|---|---|---|---|--|
| 1
3.0mmD
Round Bur
1203 | 2
2.3mmD
Drill, 22mmL
SV2.3DN | 3
Paralleling
Tool (Qty: 4)
PPAR | 4
2.8mmD
Drill, 22mmL
SV2.8DN | 5
3.4/2.8mmD
Step Drill,
22mmL
TSV3DN | 6
3.4mmD
Drill, 22mmL
SV3.4DN | 7
3.8/3.4mmD
Step Drill,
22mmL
TSV3.8DN | 8
3.8mmD
Drill, 22mmL
SV3.8DN | 9
4.4/3.8mmD
Step Drill,
22mmL
TSV4DN | 10
5.1mmD
Drill, 22mmL
SV5.1DN | 11
5.7/5.1mmD
Step Drill,
22mmL
TSV6DN |
| 12
Tapered
Pilot Drill,
2.1/ 1.6mmD,
8mmL - 11.5mmL
0201DSN*
(or 0201) | 13
2.3mmD
Drill, 16mmL
SV2.3DSN | 14
2.8mmD
Drill, 16mmL
SV2.8DSN | 15
3.4/2.8mmD
Step Drill,
16mmL
TSV3DSN | 16
3.4mmD
Drill, 16mmL
SV3.4DSN | 17
3.8/3.4mmD
Step Drill,
16mmL
TSV3.8DSN | 18
3.8mmD
Drill, 16mmL
SV3.8DSN | 19
4.4/3.8mmD
Step Drill,
16mmL
TSV4DSN | 20
5.1mmD
Drill, 16mmL
SV5.1DSN | 21
5.7/5.1mmD
Step Drill,
16mmL
TSV6DSN | |



* Call a sales representative for availability in the kit.

ZIMMER GUIDED SURGERY DRILL MODULE

THE ZIMMER GUIDED SURGERY MODULE IS SOLD SEPARATELY AND SNAPS INTO THE TAPERED SCREW-VENT SURGICAL KIT

Port #	Drill Bit Description	Model
41	2.3mmD Drill, 19mmL	STR23D19
42	2.8/2.4mmD Step Drill, 19mmL	STP28D19
43	2.8mmD Drill, 19mmL	STR28D19
44	3.4/2.8mmD Step Drill, 19mmL	STP34D19
45	3.4mmD Drill, 19mmL	STR34D19
46	3.8/3.4mmD Step Drill, 19mmL	STP38D19
47	3.8mmD Drill, 19mmL	STR38D19
48	4.4/3.8mmD Step Drill, 19mmL	STP44D19
49	2.3mmD Drill, 25mmL	STR23D25
50	2.8/2.4mmD Step Drill, 25mmL	STP28D25
51	2.8mmD Drill, 25mmL	STR28D25
52	3.4/2.8mmD Step Drill, 25mmL	STP34D25
53	3.4mmD Drill, 25mmL	STR34D25
54	3.8/3.4mmD Step Drill, 25mmL	STP38D25
55	3.8mmD Drill, 25mmL	STR38D25
56	4.4/3.8mmD Step Drill, 25mmL	STP44D25

22	Drill Extender DE	23	3.7mmD Bone Tap TT3.7	24	4.1mmD Bone Tap TT4.1	25	4.7mmD Bone Tap TT4.7	26	6.0mmD Bone Tap TT6.0	27	2.5mmD GemLock® Hex Drill RHD2.5	28	2.5mmD GemLock Hex Tool, Short RH2.5	29	2.5mmD GemLock Hex Tool, Long RHL2.5		
30	3.0mmD Hex Insertion Drill HX3.0D	31	3.0mmD Hex Insertion Tool, 17mmL HX3.0-S	32	3.0mmD Hex Insertion Tool, 25mmL HXL3.0-S	33	Removal Tool TLRT2	34	1.25mmD Hex Driver with GemLock Retention, 22mm HXGR1.25	35	1.25mmD Hex Driver with GemLock Retention, 30mm HXLGR1.25	36	1.25mmD Hex Tool, 17mmL HX1.25	37	1.25mmD Long Hex Tool, 22mmL HXL1.25	38	1.25mmD Hex Drill HX1.25D

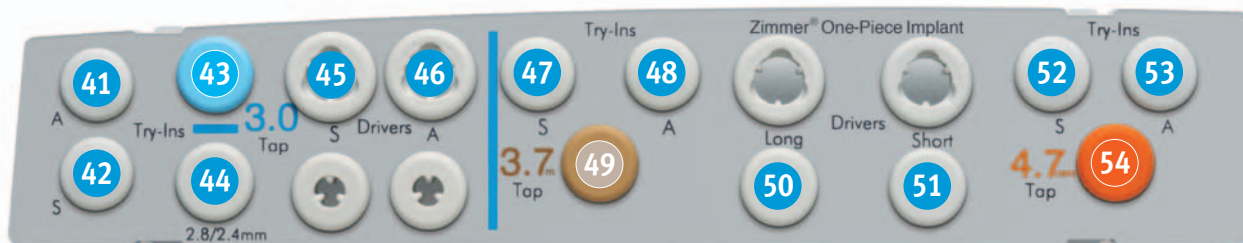
39	GemLock Retaining Square Ratchet RSR	40	Screwdriver Handle with Square Connection SSHS
----	---	----	---



For maximum cutting efficiency, replace drills frequently.

ZIMMER ONE-PIECE UPGRADE

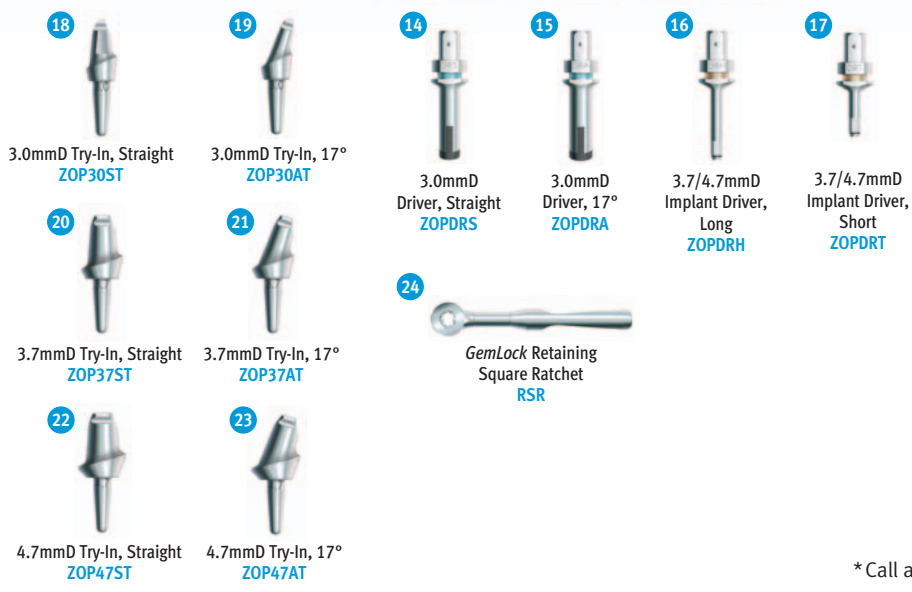
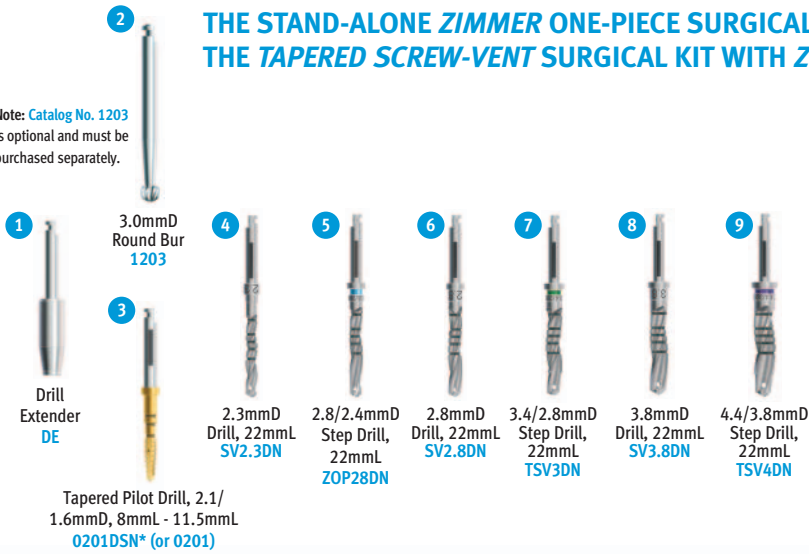
THE ZIMMER ONE-PIECE UPGRADE IS SOLD SEPARATELY AND SNAPS INTO THE TAPERED SCREW-VENT SURGICAL KIT.



ZIMMER ONE-PIECE SURGICAL KIT

THE STAND-ALONE ZIMMER ONE-PIECE SURGICAL KIT IS AN ALTERNATIVE TO THE TAPERED SCREW-VENT SURGICAL KIT WITH ZIMMER ONE-PIECE UPGRADE.

Note: Catalog No. 1203 is optional and must be purchased separately.



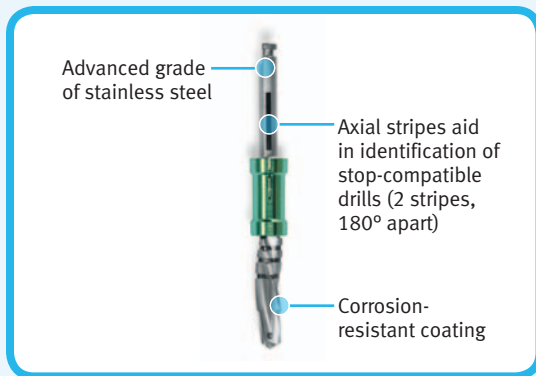
* Call a sales representative for availability in the kit.

ZIMMER DRILL STOP KIT

The Drill Stops are used to limit drilling depth from bone level during osteotomy preparation for *Trabecular Metal*, *Tapered Screw-Vent*, *Zimmer One-Piece* and *AdVent* Implants. The Drill Stops are made from Grade 5 titanium alloy.

Each *Zimmer* Drill Stop Kit row is organized by length of implant being placed. Engraved on the Drill Stops are implant length indications. Indications followed by “L” correspond to the *Driva* Drill, 17mm (22mm). Indications followed by “S” correspond to the *Driva* Drill, 11mm (16mm). Each *Zimmer* Drill Stop Kit column is organized by drill diameter. The Drill Stops are color-coded to correlate with drill diameters.



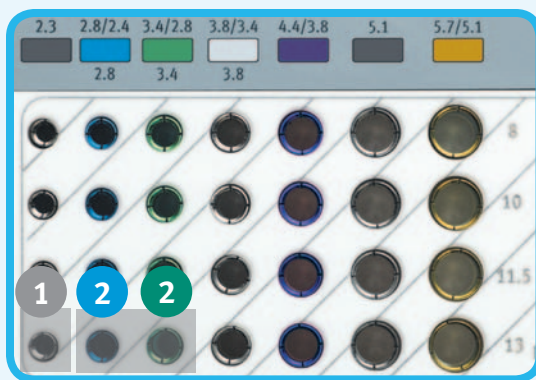


DRÍVA DRILL COMPATIBILITY

The Drill Stops are designed for use with *Dríva* Drills that have a black axial stripe (16mmL and 22mmL).

Note: Drill Stops in the last three rows of the 1st column labeled with implant diameter “2.3” for use with 11/16mm Drills are also compatible with the 0201DSN 2.1mm/1.6mmD Tapered Pilot Drill for limiting drilling depth to 8, 10 and 11.5mm.

0201DSN



SELECTING A DRILL STOP

Sample Sequence – Osteotomy for a 3.7mmD x 13mmL *Tapered Screw-Vent* Implant, using a 17/22mmL *Dríva* Drill.

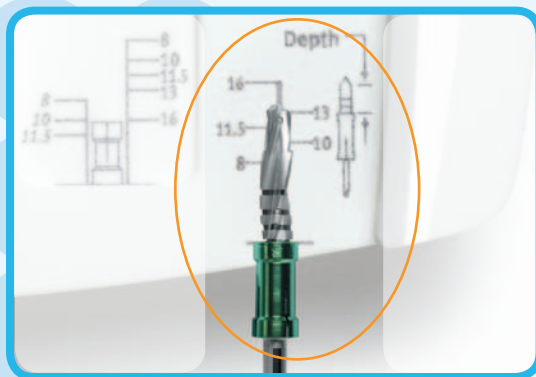
Step 1: From the 13mmL implant row, select the stop for a 2.3mmD Pilot Drill.

Step 2: From the same row, select the stop for a 2.8mmD drill (final for soft bone) or skip to the stop for a 3.4/2.8mmD Step Drill (final for dense bone).



PLACING THE DRILL STOP ON THE DRILL

Insert the drill tip into the appropriate Drill Stop located in the *Zimmer Drill Stop Kit* until firmly seated. Withdraw the drill with the Drill Stop on the drill.

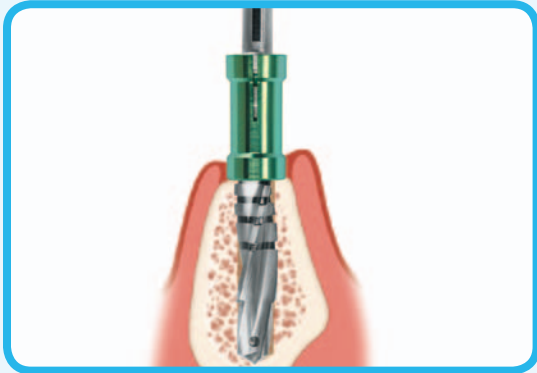


VERIFYING THE DRILLING DEPTH

Verify the drilling depth with the assembled Drill Stop by using the Drill Depth Guide.

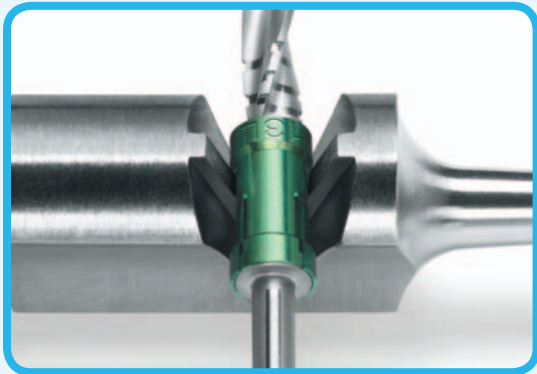
Note: The top of the laser/score line markings (0.5mm in height) on the drills are in excess of the length of the implant to be placed by 1.25mm (8mmL is actually 9.25mm). This added length is to accommodate for the design of the drill point. The 2.3mmD Drill is the only drill that is close to the actual implant length (i.e., 8mmL is actually 8.25mmL).

ZIMMER DRILL STOP KIT



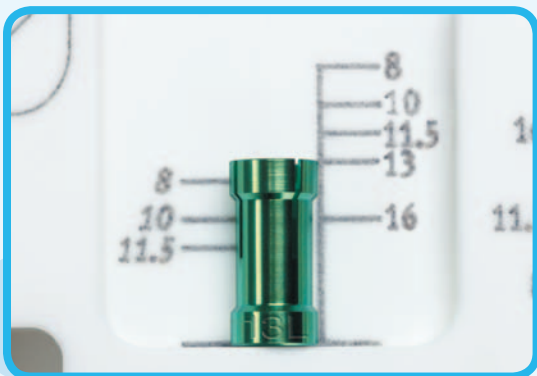
CREATING THE OSTEOTOMY

Create the osteotomy to the pre-determined depth.



REMOVING THE DRILL STOP FROM THE DRILL

Disengage the Drill Stop using the Multi-Tool or by hand. Store used stops in the storage bowl.


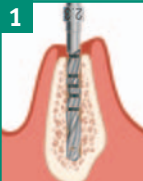
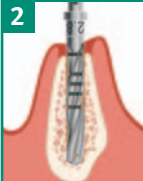
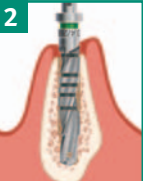
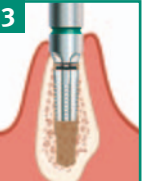


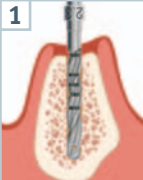
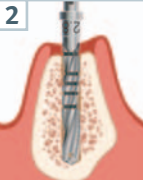
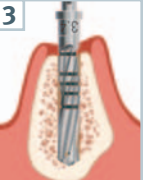
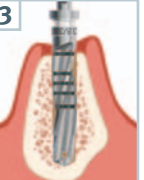
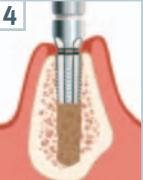


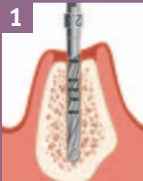
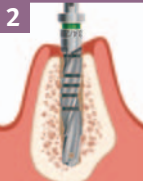
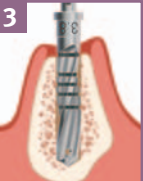
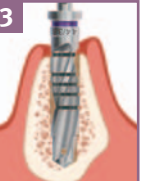
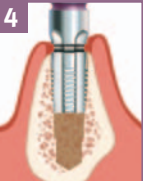


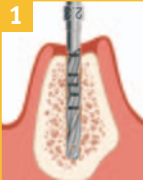
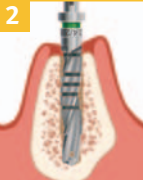
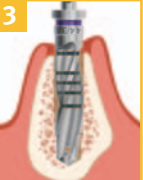

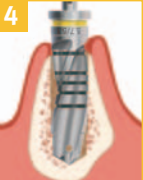




REPLACING THE DRILL STOPS IN THE KIT




Following cleaning, and before placing the drill stop back in the kit, verify the Drill Stop's location in the kit by using the Drill Stop Guide.

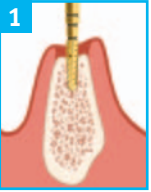
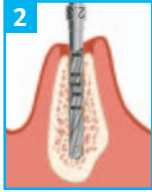
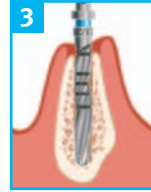
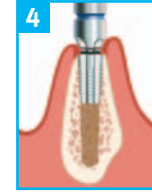
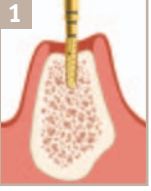
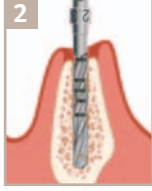
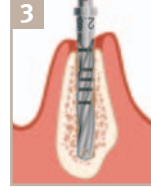
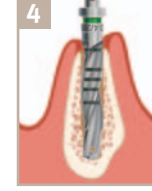
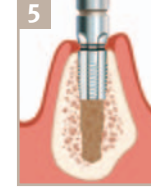






Note: Replacement drill stops are available in case of loss or wear.

TAPERED SCREW-VENT, TRABECULAR METAL AND ADVENT IMPLANTS

 <p>3.7mmD</p>	<h3>3.7mmD Tapered Screw-Vent Implant (3.5mmD Platform)</h3>					<p>ATTENTION: Follow the same protocol for <i>Trabecular Metal</i> Implants in corresponding diameters and for <i>AdVent</i> Implants with corresponding diameters, but for <i>AdVent</i> Implants utilize the Countersink Drill (AVCSD for 3.5mmD and 4.5mmD platforms / AV6CSD for 5.7mmD platform) prior to the Cortical Bone Tap for esthetics in dense bone. When placing the <i>Trabecular Metal</i> Dental Implant in dense bone, do not under-prepare the osteotomy.</p> <p>For detailed cleaning and sterilization instructions, refer to the Instructions for Use provided with the Zimmer Instrument Kit System.</p>	
 <p>1 SV2.3DN 2.3mmD Drill</p>	 <p>2 FOR SOFT BONE SV2.8DN 2.8mmD Drill</p>	 <p>2 FOR DENSE BONE TSV3DN 3.4/2.8mmD Drill</p>	 <p>3 OPTIONAL FOR DENSE BONE TT3.7 3.7mmD Cortical Bone Tap</p>				
							
<h3>4.1mmD Tapered Screw-Vent Implant (3.5mmD Platform)</h3>							
 <p>4.1mmD</p>	 <p>1 SV2.3DN 2.3mmD Drill</p>	 <p>2 SV2.8DN 2.8mmD Drill</p>	 <p>3 FOR SOFT BONE SV3.4DN 3.4mmD Drill</p>	 <p>3 FOR DENSE BONE TSV3.8DN 3.8/3.4mmD Drill</p>	 <p>4 OPTIONAL FOR DENSE BONE TT4.1 4.1mmD Cortical Bone Tap</p>		
							
<h3>4.7mmD Tapered Screw-Vent Implant (4.5mmD Platform)</h3>							
 <p>4.7mmD</p>	 <p>1 SV2.3DN 2.3mmD Drill</p>	 <p>2 TSV3DN 3.4/2.8mmD Drill</p>	 <p>3 FOR SOFT BONE SV3.8DN 3.8mmD Drill</p>	 <p>3 FOR DENSE BONE TSV4DN 4.4/3.8mmD Drill</p>	 <p>4 OPTIONAL FOR DENSE BONE TT4.7 4.7mmD Cortical Bone Tap</p>		
							
<h3>6.0mmD Tapered Screw-Vent Implant (5.7mmD Platform)</h3>							
 <p>6.0mmD</p>	 <p>1 SV2.3DN 2.3mmD Drill</p>	 <p>2 TSV3DN 3.4/2.8mmD Drill</p>	 <p>3 TSV4DN 4.4/3.8mmD Drill</p>	 <p>4 FOR SOFT BONE SV5.1DN 5.1mmD Drill</p>	 <p>4 FOR DENSE BONE TSV6DN 5.7/5.1mmD Drill</p>	 <p>5 OPTIONAL FOR DENSE BONE TT6.0 6.0mmD Cortical Bone Tap</p>	
							

ZIMMER ONE-PIECE IMPLANTS

 <p>3.0mmD</p>	3.0mmD Zimmer One-Piece Implant (3.5mmD Prosthetic Margin)					
 <p>3.7mmD</p>	3.7mmD Zimmer One-Piece Implant (4.5mmD Prosthetic Margin)					
 <p>4.7mmD</p>	4.7mmD Zimmer One-Piece Implant (5.5mmD Prosthetic Margin)					

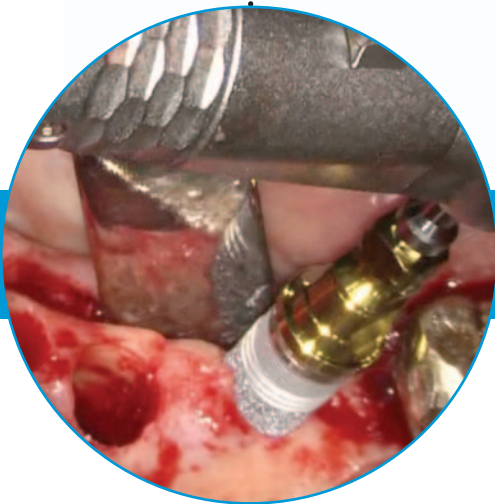
<p>1</p>  <p>0201DSN* 2.1/1.6mmD, 8mmL - 11.5mmL Drill</p>	<p>2</p>  <p>SV2.3DN 2.3mmD Drill</p>	<p>3</p>  <p>ZOP28DN 2.8/2.4mmD Drill</p>	<p>4</p>  <p>OPTIONAL FOR DENSE BONE ZOPTT30 3.0mmD Cortical Bone Tap</p>		
<p>1</p>  <p>0201DSN* 2.1/1.6mmD, 8mmL - 11.5mmL Drill</p>	<p>2</p>  <p>SV2.3DN 2.3mmD Drill</p>	<p>3</p>  <p>SV2.8DN 2.8mmD Drill</p>	<p>4</p>  <p>TSV3DN 3.4/2.8mmD Drill</p>	<p>5</p>  <p>OPTIONAL FOR DENSE BONE ZOPTT37 3.7mmD Cortical Bone Tap</p>	
<p>1</p>  <p>0201DSN* 2.1/1.6mmD, 8mmL - 11.5mmL Drill</p>	<p>2</p>  <p>SV2.3DN 2.3mmD Drill</p>	<p>3</p>  <p>TSV3DN 3.4/2.8mmD Drill</p>	<p>4</p>  <p>FOR SOFT BONE SV3.8DN 3.8mmD Drill</p>	<p>4</p>  <p>FOR DENSE BONE TSV4DN 4.4/3.8mmD Drill</p>	<p>5</p>  <p>OPTIONAL FOR DENSE BONE ZOPTT47 4.7mmD Cortical Bone Tap</p>

* Call a sales representative for availability. 0201 may also be utilized.

For detailed cleaning and sterilization instructions, refer to the Instructions for Use provided with the *Zimmer* Instrument Kit System.

Note: 3.0mmD and 3.7mmD *Zimmer* One-Piece Implants have a dense bone protocol only.

SURGICAL PROCEDURES



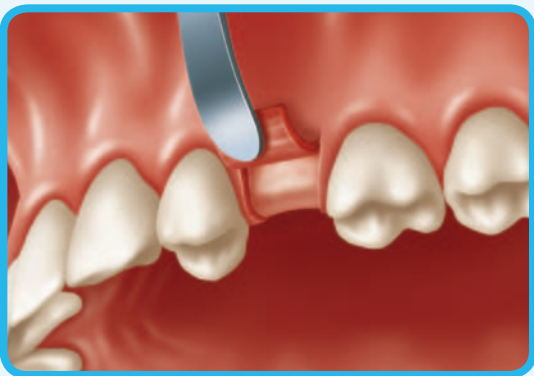
SITE PREPARATION



MAKING THE INITIAL INCISION

Make a mesiodistal incision along the alveolar crest through the mucoperiosteum and attached gingiva to the bone.

Flap and incision designs may vary due to clinician preference. Flapless surgery is only recommended when adequate bone quantity and quality have been established through appropriate diagnostic procedures.

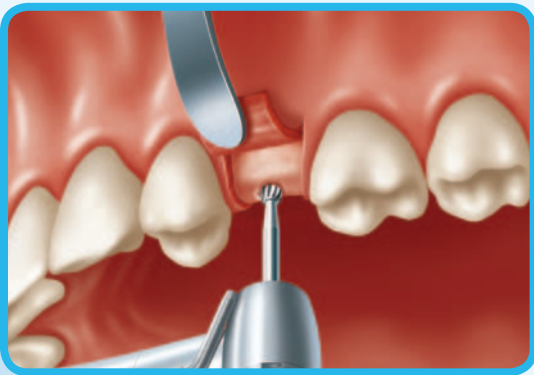


EXPOSING THE IMPLANT SITE

The incision should be long enough to permit adequate reflection and a broad field of view without tearing the tissue. Occasionally, vertical releasing incisions may be employed.

Using a periosteal elevator, carefully lift the periosteum to expose the alveolar bone only as necessary to provide an adequate surgical working area.

Place retractors or sutures to hold the soft tissues.

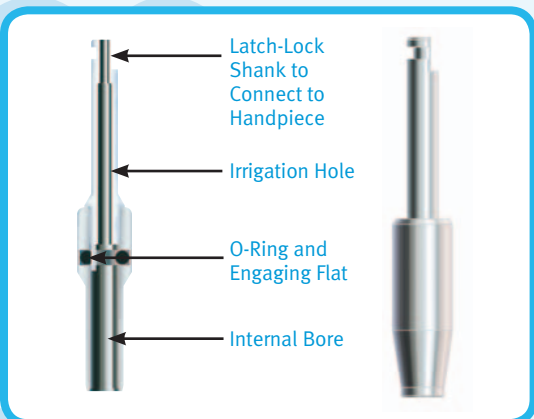


REMOVING BONE IRREGULARITIES AND ASSESSING IMPLANT SITE

Remove any spinous ridges or other bone irregularities using the Round (Rosette) Bur [1203] or a Rongeur Forcep. Keep bone removal to a minimum. Insufficient bone height/width and abnormal defects or contours not previously detected may now contraindicate placement of the implant.

Maintain previously discussed requirements for ridge width and implant requirements.

Ridge contour should be adequately palpated to estimate an angle of insertion which will achieve parallelism with other implants and natural tooth abutments where indicated.

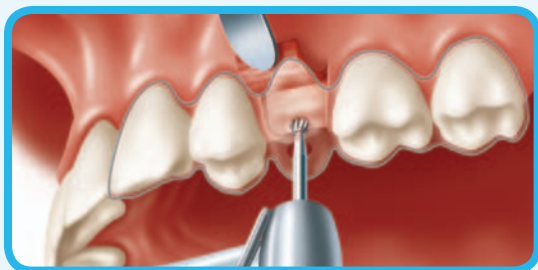


USING THE DRILL EXTENSION

Use the drill extension when additional length is required due to interference caused by adjacent teeth. The Drill Extender [DE] extends the effective access of the cutting blade of the drill by 10mm.

The drill extension has a standard latch-lock shank with a cylindrical shaft to accommodate the latch-lock type drill into the extension. The drill engages an anti-rotational flat and an O-Ring which holds the drill in position within the extender.

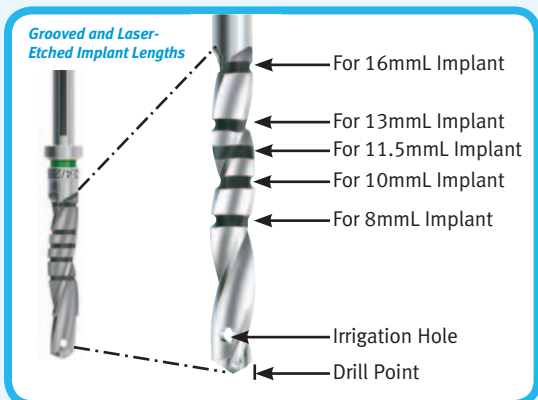
Do not use with drills other than the standard latch-lock type or exceed speeds of 850 rpm with the drill extension.



MARKING THE IMPLANT SITE

Seat the surgical guide in place to assist in marking the implant sites. The guide can be kept in place during the first stages of the drill sequence to help with the inclination as well as spacing of the implant sites relative to the proposed restoration.

Use copious external irrigation with the Round (Rosette) Bur [1203] and create a dimple through the dense ridge crest in the area of each proposed implant site. The dimple helps to prevent the surgical drills from drifting (chattering) from the proposed drill site.



USING THE SURGICAL DRILLS

Reusable drills are designed to be used with both internal and external irrigation with a surgical unit that can supply a range of drilling speeds from 15-2000 rpm with sufficient torque.

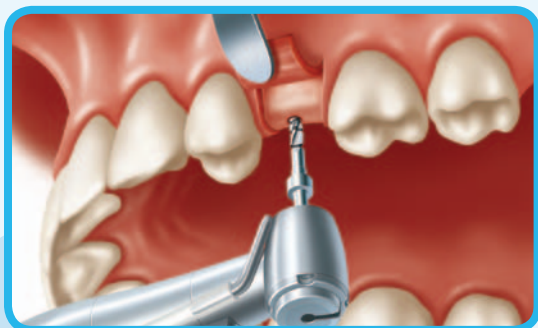
A recommended range for drilling is between 600-850 rpm, although clinicians may vary from this range in their protocol.

Note: The top of the laser/score line markings (0.5mm in height) on the drills are in excess of the length of implant to be placed by 1.25mm (8mmL is actually 9.25mL). This added length is to accommodate for the design of the drill point. The 2.3mmD Pilot Drill [SV2.3DN, SV2.3DSN] is the only drill that is close to the actual length (i.e., 8mmL is actually 8.25mL).



USING THE SURGICAL DRILLS WITH DRILL STOPS

The Drill Stops in the *Zimmer Drill Stop Kit* are used to limit drilling depth from bone level. Drill stop compatible drills are marked with black axial stripes. To place the Drill Stop on the drill, insert the drill tip into the appropriate Drill Stop located in the *Zimmer Drill Stop Kit* until firmly seated. Withdraw the drill with the Drill Stop in place. Verify the drilling depth using the Drill Depth Guide on the kit. For additional information on the *Zimmer Drill Stop Kit*, see pages 41-43.

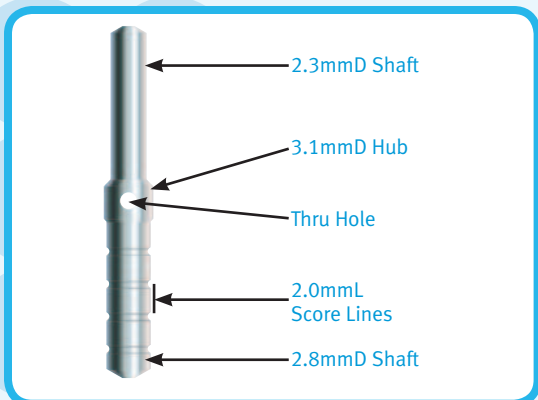


INITIATING THE OSTEOTOMY

Perform all drill procedures with a straight up-and-down motion in order to avoid creation of an oval-shaped osteotomy. This pumping action in combination with copious irrigation will also help to minimize excessive heat generation and preserve the vitality of bone. The system should deliver an adequate flow of irrigation (40-100ml/min) for a cooling, low-trauma surgical procedure.

Note: Use the hand piece designed for surgical motors only. This will ensure that compressed coolant air is not introduced to the surgical site.

Use the 2.3mmD Drill to create a pilot hole to the depth of the implant to be used. Flush the hole to remove all debris.



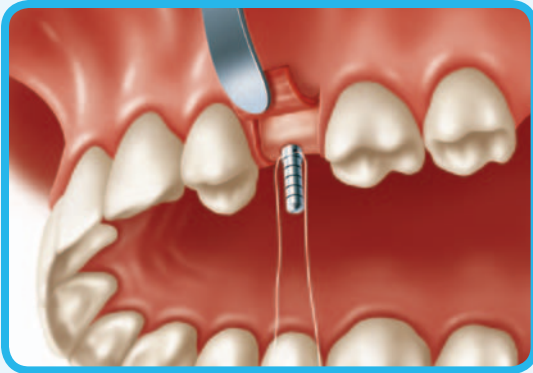
USING THE PARALLELING PIN

The Paralleling Pin [PPAR] is designed with opposing ends having two diameters, 2.3mmD and 2.8mmD. This enables the clinician to use the pins in the first two steps of the drilling sequence to ensure correct placement and alignment of the implants.

Larger diameter drills should follow the path created by the 2.3mmD and 2.8mmD drills.

The 2mmL score lines on the 2.8mmD side of the Paralleling Pin can supply the clinician with an indication of height available for the restorative aspect of the procedure.

SITE PREPARATION

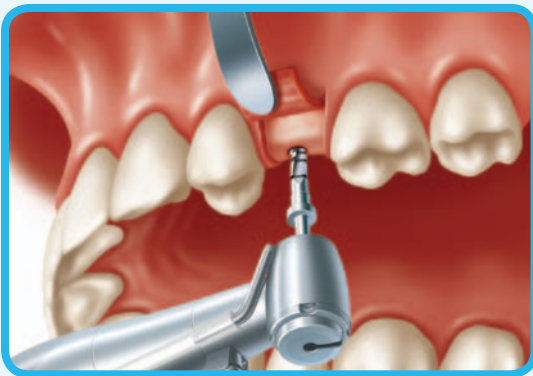


INSERTING THE PARALLELING PIN

Thread floss through the hole in the middle of the pin for retention to prevent patient aspiration.

Insert the smooth side of the Paralleling Pin into the first 2.3mmD osteotomy and confirm placement and alignment relative to the surgical guide.

Use the first pin as a guide and continue to drill the required sites to 2.3mm diameter, inserting pins in each of the holes after they have been drilled and flushed to remove the debris.

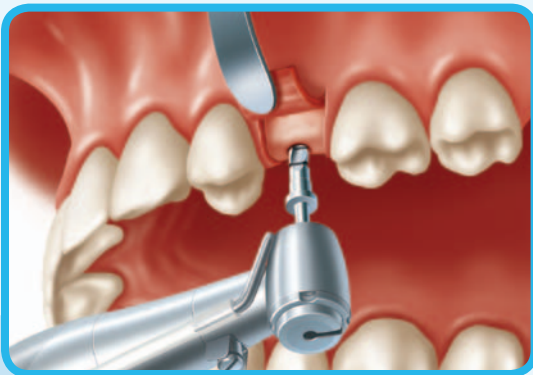


DRILLING THE OSTEOTOMY

Utilize the next drill in the drilling sequence for the implant diameter being placed to create an intermediate hole to the depth of the implant to be used. Utilize the 2.8mmD side of the Parallel Pin when appropriate.

Note: Use testing gauge [02139800] to check the condition of latch-lock bur shanks before every surgery. Refer to the testing gauge IFU for step-by-step instructions.

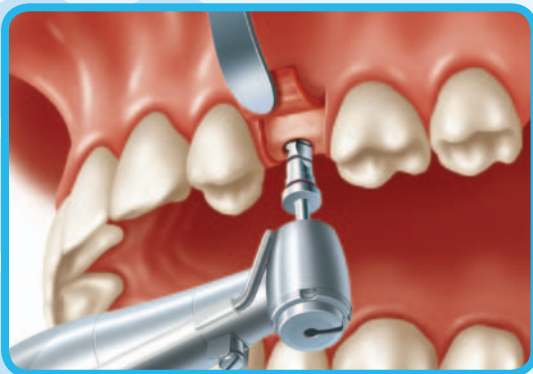
Note: Clean drill heads often to remove debris and ensure a sharp cutting surface. In conjunction with a cleaning wire [NM1940], a 25-gauge needle can be used to clean the drill's irrigation hole. A 30-gauge needle is required for drills that are 2.8mmD or narrower. Due to the density of bone commonly found in the symphysis region, newer, sharp drills are recommended.



INTERMEDIATE AND FINAL SIZING OF OSTEOTOMIES

Continue widening the osteotomy by following the appropriate drilling sequence for the implant diameter being placed, considering bone quality prior to selection of the final drill. (See drilling sequences on page 42).

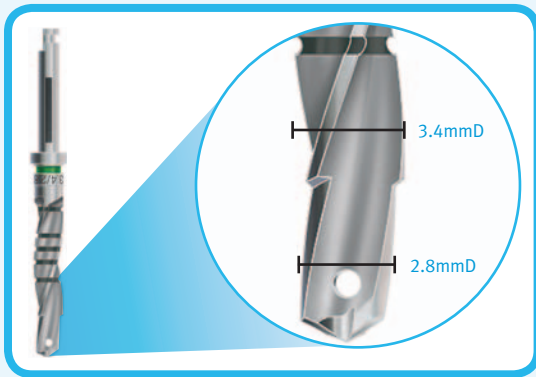
Note: When placing the *Trabecular Metal* Dental Implant in dense bone, do not under-prepare the osteotomy.



STRAIGHT DRILL FOR SOFT BONE

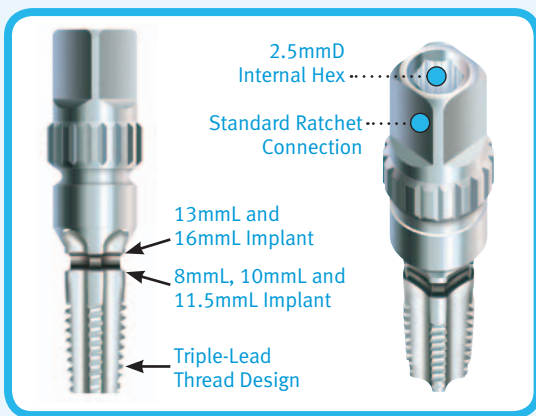
Use the straight intermediate drills as the final drill when placing implants into soft bone according to the appropriate drilling sequence for the implant diameter being placed.

(See drilling sequences on page 42 and additional information regarding soft and dense bone protocols on pages 8 and 49).



STEPPED DRILLS FOR DENSE BONE

Stepped drills for final sizing of the osteotomy are available when placing tapered implants in dense bone according to the appropriate drilling sequence for the implant diameter being placed (see drilling sequences on page 42). These drills are designed to accommodate the varying lengths of tapered implants without having to have length-specific tapered drills. The drill has two diameters of straight-walled design incorporated into one drill. This is designed to allow the implants to obtain maximum engagement into bone no matter the length of implant being used. The length of the stepped area is approximately 5mm from the point of the drill to the start of the wider portion. The stepped drills have color-coded bands based on implant color coding. (See color-coding charts on pages 35-36).



CORTICAL BONE TAPS

For placement of implants in dense cortical bone, bone taps are designed with a thread having the same configuration as the implant. Above the threaded area the tool flares out slightly to open the cortical plate to receive the wider neck of the implant.

Cortical bone taps may be utilized to reduce insertion torque when placing implants in dense cortical bone. Above the threaded area the tool flares out slightly to open the cortical plate to receive the wider neck of the implant.

Typically, taps are only advanced through the dense cortical plate, however, the laser etch line indicates the maximum tap depth.



USING CORTICAL BONE TAPS

Use the Cortical Bone Tap in conjunction with the *GemLock* Retaining Square Ratchet [RSR] and rotate into the osteotomy.

In areas where there is limited space between the surrounding dentition, a 2.5mmD *GemLock* Hex Tool [RH2.5, RHL2.5] can be inserted into the back end of the Cortical Bone Tap to increase the vertical height of the tool allowing attachment of the ratchet. A 2.5mmD Hex Drill [RHD2.5] can also be inserted into the recess to facilitate use with a high-torque, low-speed (15 rpm) surgical handpiece and motor.



PREPARING FOR IMPLANT PLACEMENT

Irrigate the implant sites with sterile water and then suction prior to implant placement, ensuring no debris is left at the base or attached to the vertical walls of the osteotomy.

Any debris could hinder the vertical placement of the implant as well as possibly increase the insertion torque above acceptable limits.

SOFT & DENSE BONE PROTOCOLS



FINAL SIZING OF OSTEOTOMY

Drill the osteotomy according to the density of the bone surrounding the proposed implant site.

In areas where the bone is commonly referred to as soft bone, it is often advocated to stop the drilling sequence at the straight drill before the final step drill.

Soft bone protocol: 2.8mmD straight drill for 3.7mmD implants, 3.4mmD for 4.1mmD implants, 3.8mmD for 4.7mmD implants and 5.1mmD for 6.0mmD implants.

Dense bone protocol: 3.4/2.8mmD stepped drill for 3.7mmD implants, 3.8/3.4mmD for 4.1mmD implants, 4.4/3.8mmD for 4.7mmD implants and 5.7/5.1mmD for 6.0mmD implants. Use of the bone tap is optional but may be necessary in very dense bone.



PLACING IMPLANT INTO OSTEOTOMY

Soft bone protocol: From time of initial placement of the implant in the straight hole, the implant will start to compress the bone. This occurs due to the fact that the hole size is slightly smaller than the apex size of the implant. Example: Using the 3.7mmD implant with a 3.0mmD apex and inserting into a hole with a 2.8mmD opening.

Dense bone protocol: From time of initial placement of the implant in the stepped hole, the implant will drop almost a third of its length before stopping. This occurs because the hole size is bigger than the apex size of the implant. Example: Using the 3.7mmD implant with a 3.0mmD apex and inserting into a 3.4mmD opening.



PLACING IMPLANT INTO OSTEOTOMY, CLOSE UP

Soft bone protocol: Compression of bone occurring from time of initial insertion.

Dense bone protocol: Implant drops into hole almost a third of its thread length at time of initial insertion. The Fixture Mount/Transfer may be removed and the *GemLock* Hex Tool [RH2.5] used to directly engage the implant for insertion with the screwdriver handle [SSHS].



COMPLETING PLACEMENT OF IMPLANT

Soft bone protocol: Compression of bone occurring the full length of the implant, improving initial stability from time of placement.

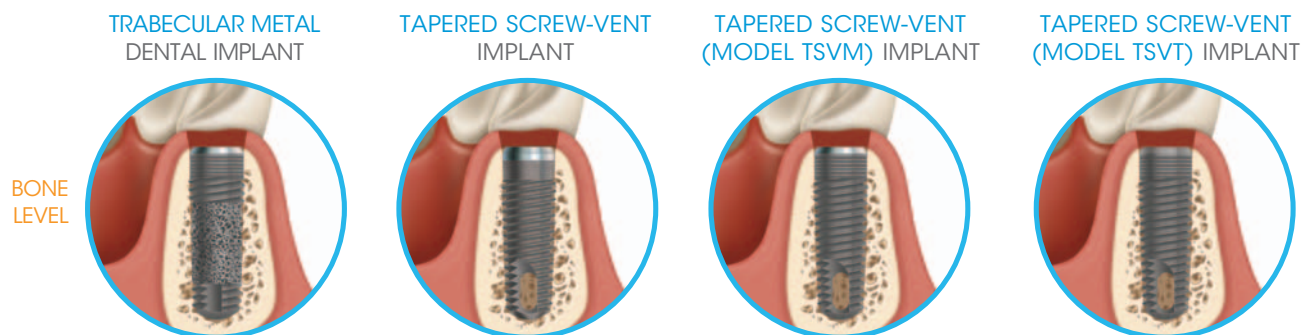
Dense bone protocol: As the implant progresses, the thread will engage the walls of the osteotomy. When fully seated the 3.7mmD apical end of the implant, will engage the 3.8mmD section of the osteotomy. The amount of engagement will increase over the length of the implant to the 4.7mmD coronal threads engaging the 4.4mmD section of the osteotomy. The inner dimension (4.4mmD maximum) of the implant threaded area contacts the walls of the osteotomy, but does not compress. (Measurements refer to 4.7mmD implant sequence).

Note: 3.0mmD and 3.7mmD *Zimmer* One-Piece Implants have a dense bone protocol only. See drilling sequences on page 45.

COLLAR DEPTH ADJUSTMENT

Trabecular Metal and *Tapered Screw-Vent* Implants are available in a variety of crestal options to fulfill your clinical needs. Each of Zimmer's crestal configurations is designed to create favorable conditions for crestal bone maintenance.

Each clinical situation requires case-specific evaluation to determine ideal implant placement. The *Trabecular Metal* and *Tapered Screw-Vent* Implants are designed to be placed even with the crestal bone whether this is obtained by flattening the ridge or grafting around the implant is a clinical choice based on the patient need.

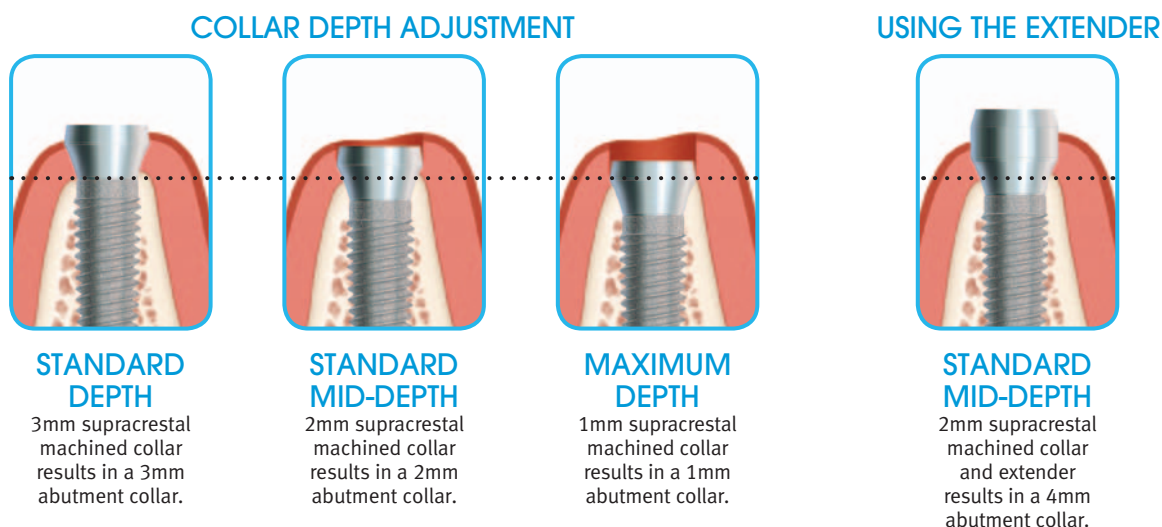


AdVent Implants are designed with the flexibility to vary supracrestal placement of the fluted machined neck. By adjusting the depth of the osteotomy and the contouring of the thick cortical layer with the aid of a Countersink Drill [AVCSD or AV6CSD], an additional depth of between 1-2mm can be obtained.

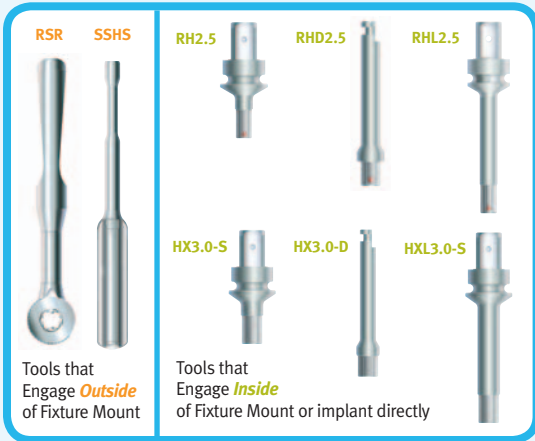
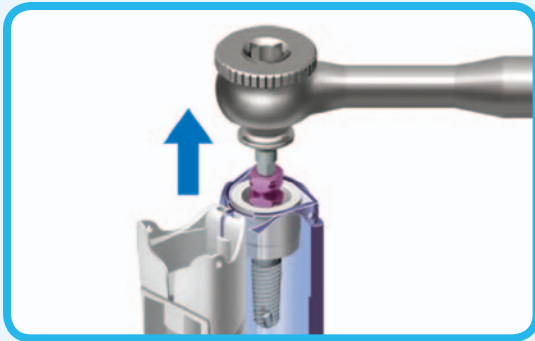
The adjustment of collar height is a clinical choice and might be performed for the following reasons:

- 1) In esthetic areas of the mouth, the implant interface can be placed sub-gingivally at time of implant placement. The soft tissue profile is maintained during the healing process by the addition of the Implant Extender. The extender is added to the top of the implant prior to the placement of the Surgical Cover Screw.
- 2) The 2mm fluted neck height can be adjusted to accommodate variance in height of bone profile in multi-unit cases, vertical clearance from opposing dentition, soft tissue height or to obtain an assortment of abutment heights (shown below).

Note: The abutment height adjustment only applies to the 4.5mmD platform. The 5.7mmD platform *AdVent* Implant uses all the 6.0mmD *Tapered Screw-Vent* prosthetic components (which are not compatible with the Implant Extender).



IMPLANT PLACEMENT



REMOVING THE IMPLANT FROM THE VIAL

Remove the implant outer vial from the box and open the outer vial to break the seal. Drop the sterile inner vial and contents onto a sterile field. Flip the white top of the inner vial open by pressing on the flat side with access hole. Press the top to the inner vial body to lock in the top. For further instructions see the Packaging Instructions for Use on pages 75-76.

The implant is supplied pre-attached to a multi-functional Fixture Mount/Transfer for easy delivery. Remove the implant from the inner vial by using one of the delivery instruments (see the next section).

Note: The supplied Surgical Cover Screw is located in the lid of the inner vial with an access hole for the *GemLock* Hex Tool.

DELIVERING THE IMPLANT TO THE SITE

The implant may be driven manually or with the use of a surgical motor at speeds up to 30 rpm. The following instruments can be used for implant delivery to the site:

- 1) The *GemLock* Ratchet Retaining Square [RSR] or the Screwdriver Handle [SSHS] attached directly to the Fixture Mount/Transfer.
- 2) The *GemLock* Ratchet Retaining Square [RSR] attached to the 2.5mm *GemLock* Retaining Hex Drivers [RH2.5, RHL2.5] which engage the female hexagon of the Fixture Mount/Transfer.
- 3) The *GemLock* Ratchet Retaining Square [RSR] attached to the 2.5mm *GemLock* Retaining Hex Drivers [RH2.5, RHL2.5] or the 3.0mm Hex Driver [HX3.0-S, HXL3.0-S] inserted directly into the implant when space is limited or to facilitate placement in dense bone.
- 4) A motor handpiece attached to the 2.5mm *GemLock* Retaining Hex Driver [RHD2.5] for placement with the Fixture Mount/Transfer or for placement of an implant with a 2.5mmD internal hexagon without the Fixture Mount/Transfer, or the 3.0mm Hex Driver [HX3.0D] for placement of an implant with a 3.0mmD internal hexagon.

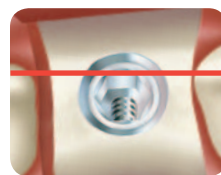
Note: The 2.5mm *GemLock* Hex Tools and Hex Drill engage the female hexagon of the Fixture Mount/Transfer (*Trabecular Metal*, *Tapered Screw-Vent* and *AdVent* Implants) or the 2.5mm internal hexagon implants directly (3.7-4.7mmD *Trabecular Metal* and *Tapered Screw-Vent* Implants). The 3.0mm *GemLock* Hex Drivers and Drill directly engage the 3.0mm internal hexagon implants (6.0mmD *Trabecular Metal*, *Tapered Screw-Vent* and *AdVent* Implants) only.

INSERTING AND ORIENTING THE IMPLANT

Gently seat the implant into the osteotomy. The tapered implants will seat into the osteotomy as described on the previous page. Thread the implant into the prepared site using the *GemLock* Retaining Square Ratchet [RSR] attached to the fixture mount or by utilizing an alternative method as described above. For *AdVent* Implant protocol, continue to page 59.

The flat side of the Fixture Mount/Transfer is manufactured to align with the flat of the implant's hex. To ensure proper orientation of the *Hex-Lock* Contour Abutments, align the flat side of the Fixture Mount/Transfer to the buccal aspect. For 20° Abutments, orient a flat side of the Fixture Mount/Transfer toward the direction of the implant angle.

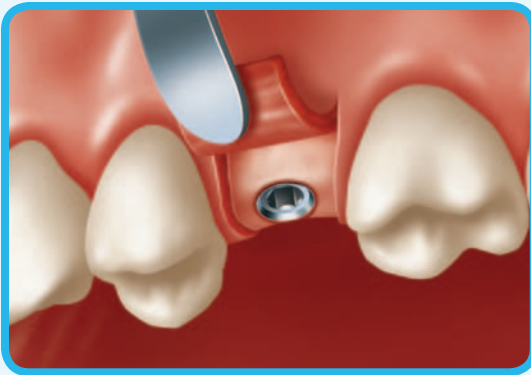
COMPLETING IMPLANT INSERTION



After the implant is seated in the desired position, use the 1.25mmD *GemLock* Hex Driver [HXGR1.25, HXLGR1.25] to unthread the Fixture Mount Screw. If unable to unthread, seat the ratchet over the Fixture Mount and use it as a counter-torque. Insert the 1.25mmD *GemLock* Hex Driver through the ratchet and loosen the screw. Disengage the Fixture Mount and Screw from the implant by gently pulling up in an axial direction.



ONE- AND TWO-STAGE PROTOCOLS

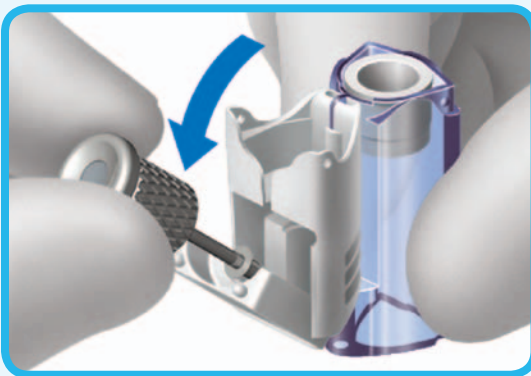


CLEANING THE SURGICAL SITE

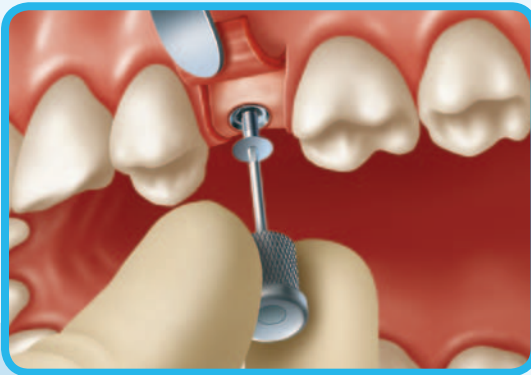
Irrigate the surgical site with sterile water and then suction, ensuring the implant's internal chamber is clear of bone and tissue debris and/or blood. This procedure will allow for the unimpeded seating of the Surgical Cover Screw, Healing Collar or Provisional Abutment.

TWO-STAGE OR ONE-STAGE PROTOCOL

In a traditional two-stage protocol, the surgical cover screw is threaded into the implant over which the tissue is sutured during implant healing. To select the surgical cover screw, unthread the surgical cover screw from its plastic mount in the lid of the inner implant vial. Use the 1.25mmD Hex Driver with *GemLock* retention, [HXGR1.25, HXLGR1.25] to engage the surgical cover screw through the access hole. Press the Hex Driver to the side to open the white flap of the lid and retrieve the surgical cover screw. Continue with the following steps on this page.



For a one-stage procedure, depending on initial implant stability and the overall treatment plan, a healing collar or provisional abutment is placed around which the tissue is sutured (See page 57 "Healing Collar Selection Guide," for instruction regarding Healing Collar Selection). (If a healing collar is used in a one-stage procedure, after the appropriate healing time has elapsed continue with step "Removing the Healing Collar" on page 56).

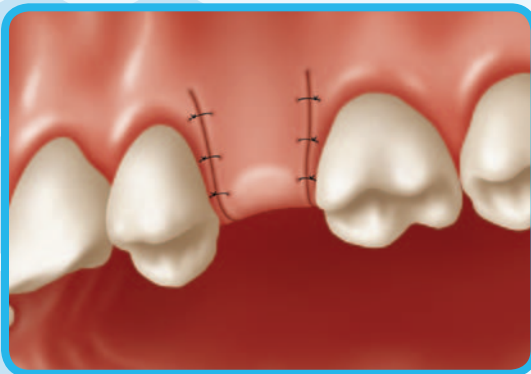


TWO-STAGE: PLACING THE SURGICAL COVER SCREW

Use the 1.25mmD Hex Driver with retentive *GemLock* feature [HXGR1.25, HXLGR1.25] to carry the Surgical Cover Screw to the opening of the implant. Gently thread the screw into the implant ensuring proper thread engagement between the two components.

Tighten using finger pressure only. The Surgical Cover Screw should fit flush with the top of the implant. This will provide a low profile, often level with the crest of the ridge. This low profile is advantageous when primary soft tissue closure is desired.

After placement of the implant and Surgical Cover Screw, take a radiograph to confirm position before closure of the soft tissue.



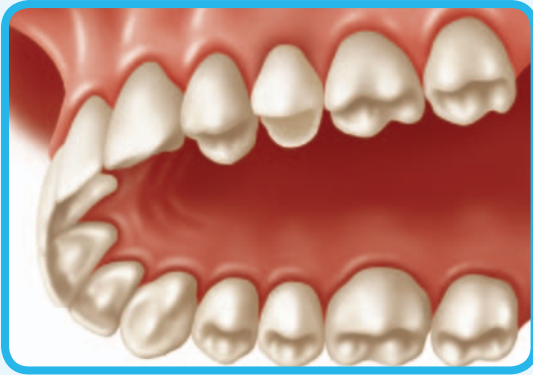
TWO-STAGE: SUTURING THE SOFT TISSUE

Carefully replace the soft tissue over the Surgical Cover Screws. Use suture material of choice and suture with one or more of the suture methodologies available (interrupted sutures shown).

Instruct the patient to follow post surgical maintenance and hygiene. Provide a provisional prosthesis that is designed to prevent any premature loading on the implants.

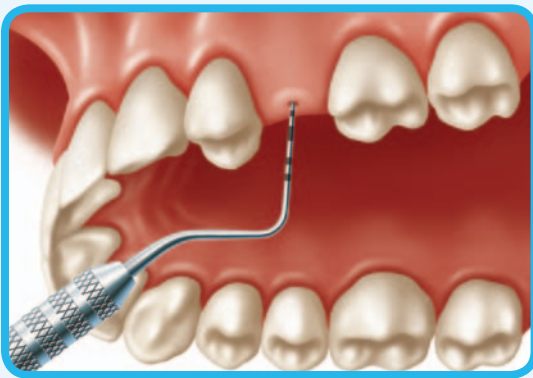
Remove the sutures after 1 to 2 weeks.

ONE- AND TWO-STAGE PROTOCOLS

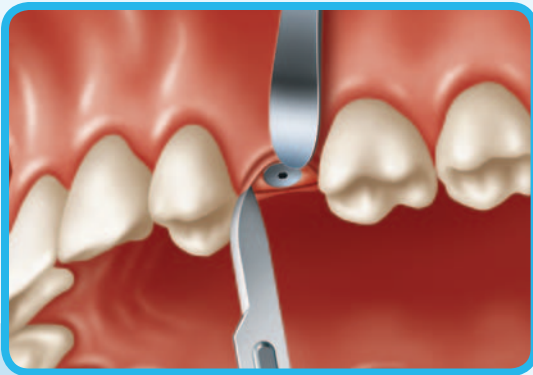
**TWO-STAGE: REMOVING THE PROVISIONAL PROSTHESIS**

Through x-ray analysis and knowledge of bone density in the surgical area, determine the time for second-stage surgical procedures.

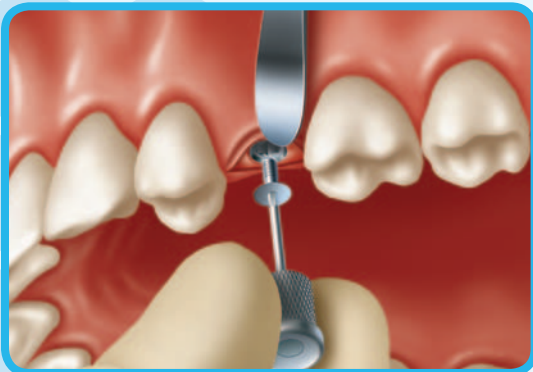
Remove the provisional prosthesis.

**TWO-STAGE: LOCATING THE SURGICAL COVER SCREW**

Locate the position of the Surgical Cover Screw by palpation of the soft tissue or with the use of a periodontal probe.

**TWO-STAGE: EXPOSING THE SURGICAL COVER SCREW**

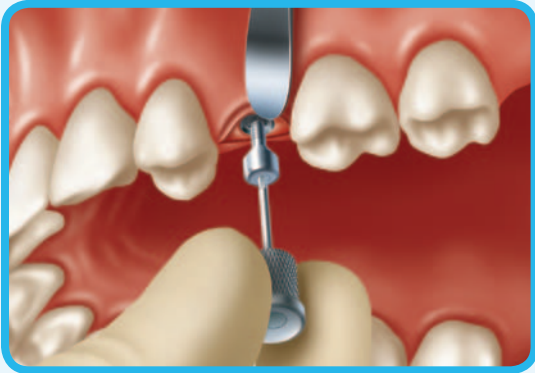
Expose the Surgical Cover Screw by using a Tissue Punch or a scalpel.

**TWO-STAGE: REMOVING THE SURGICAL COVER SCREW**

Remove any bone growth from the superior aspect of the Surgical Cover Screw. Care must be taken not to damage the implant during the process of bone removal.

Use the 1.25mmD Hex Driver with *GemLock* retention [[HXGR1.25](#), [HXLGR1.25](#)] in a counter-clockwise direction to remove the Surgical Cover Screw.

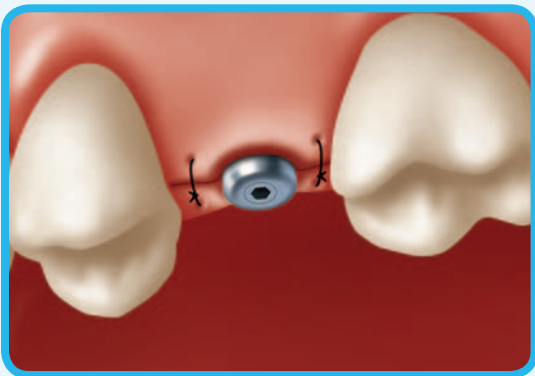
The implant can now be evaluated to determine if it is sufficiently anchored in the surrounding bone.



ONE-STAGE OR TWO-STAGE: SEATING THE HEALING COLLAR

Utilize the “Healing Collar Selection Guide” on page 57 for instruction regarding Healing Collar Selection. Irrigate the surgical site with sterile water and then suction, ensuring the implant’s internal chamber is clear of bone and tissue debris and/or blood. This procedure will allow for the unimpeded seating of the Healing Collar and complete closure of the implant’s internal chamber and prosthetic interface.

Thread the Healing Collar into the implants with a 1.25mmD Hex Driver with *GemLock* retention [HXGR1.25, HXLGR1.25] and then use finger pressure to tighten.



ONE-STAGE OR TWO-STAGE: SUTURING THE SOFT TISSUE

Carefully replace the soft tissue around the Healing Collar. Use suture material of choice and suture with one or more of the suture methodologies available (interrupted sutures shown).

Instruct the patient to follow post surgical maintenance and hygiene. Provide a provisional prosthesis that is designed to prevent any unguided loading on individual implants (i.e., the occlusal load is shared with all implants and/or surrounding dentition equally).

Remove the sutures after 1 to 2 weeks.

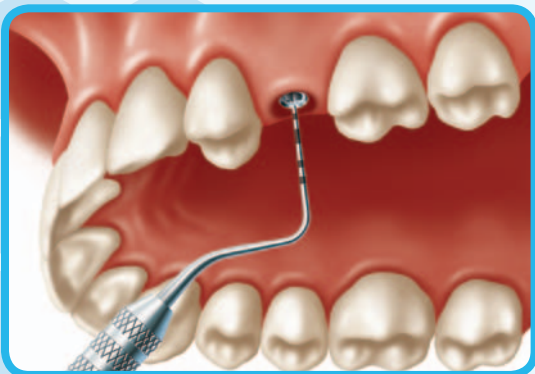


ONE-STAGE OR TWO-STAGE: REMOVING THE HEALING COLLARS

In a two-stage procedure, use the 1.25mmD Hex Driver with *GemLock* retention [HXGR1.25, HXLGR1.25] to remove the Healing Collars after a satisfactory soft tissue healing period, to be determined on a case by case basis.

If a one-stage protocol was utilized, remove the Healing Collar (or immediate provisional restoration) after the appropriate implant healing period.

The implants are now ready for the restorative phase of the implant procedure.



ONE-STAGE OR TWO-STAGE: MEASURING SOFT TISSUE DEPTH

Use a periodontal probe with 1mm demarcation lines to measure the buccolingual and mesiodistal soft tissue depth. Measurements are taken from the superior aspect of the implant to the gingival margin. Measurements will assist in determining the height of the abutment required for the restoration. Refer to the *Tapered Screw-Vent and AdVent Restorative Manual*, P/N 4941, for further restorative instructions.




















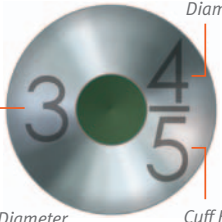
HEALING COLLAR SELECTION GUIDE

FOLLOW THE STEPS BELOW TO SELECT THE APPROPRIATE HEALING COLLAR:

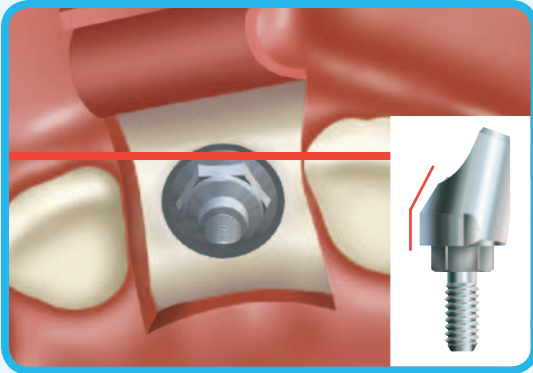
- Determine the size of the implant platform.
- Select the emergence profile that best suits the site being restored as well as type of restoration being fabricated.
- Select the diameter that matches the transfer and final abutment to be used in the respective site during the restorative phase.
- Select the length (3mm or 5mm) so that the top of the component protrudes slightly above surrounding tissue.

All vertical measurements are taken from the superior aspect of the implant.

HEALING COLLARS FOR TRABECULAR METAL AND TAPERED SCREW-VENT IMPLANTS

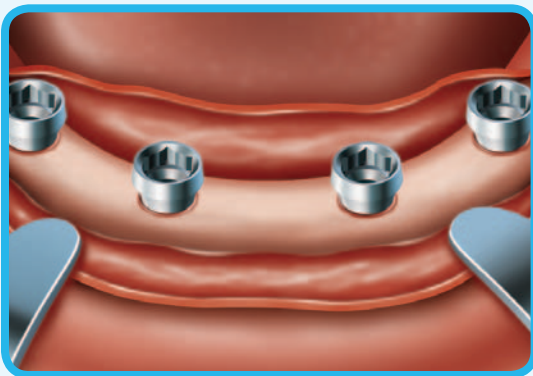
	Profile Diameter	Profile Diameter	Profile Diameter	Profile Diameter
3.5mmD Platform Diameter 	Length 3mmL  HC333	Length 3mmL  HC343	Length 3mmL  HC353	
	Length 5mmL  HC335	Length 5mmL  HC345	Length 5mmL  HC355	Length 7mmL  HC347
4.5mmD Platform Diameter 	Length 3mmL  HC443	Length 3mmL  HC453	Length 3mmL  HC463	
	Length 5mmL  HC445	Length 5mmL  HC455	Length 5mmL  HC465	Length 7mmL  HC457
5.7mmD Platform Diameter 	Length 3mmL  HC563	Length 5mmL  HC565	 <p>Emergence Profile Diameter</p> <p>Implant Platform Diameter</p> <p>Cuff Height</p>	

ALIGNING THE IMPLANT AND PLACEMENT OF HEALING COMPONENTS



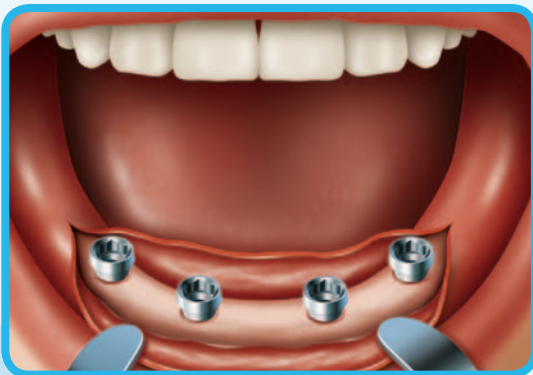
INDEXING THE IMPLANT

The flat side of the Fixture Mount/Transfer is manufactured to align with the flat of the implant's hex. To ensure proper orientation of the 20° Abutments [AVH20, AVH20/4, A5H20], orient a flat side of the Fixture Mount/Transfer toward the direction of the implant angle. To orient the two-piece 20° Angled Abutment [AVH20/4], position the flat surface of the hexagon on the implant's Fixture Mount/Transfer or Insertion Tool [HX3.0-S, HXL3.0-S or HX3.0D] either toward or opposite the desired direction of the abutment angle.



COMPLETING IMPLANT INSERTION

After the implant is seated in the desired position, use the 1.25mmD GemLock Hex Driver [HXGR1.25, HXLGR1.25] to unthread the Fixture Mount Screw. If unable to unthread, seat the ratchet over the Fixture Mount and use it as a counter torque. Insert the 1.25mmD GemLock Hex Driver through the ratchet and loosen the screw. Disengage the Fixture Mount and Screw from the implant by gently pulling up in an axial direction.



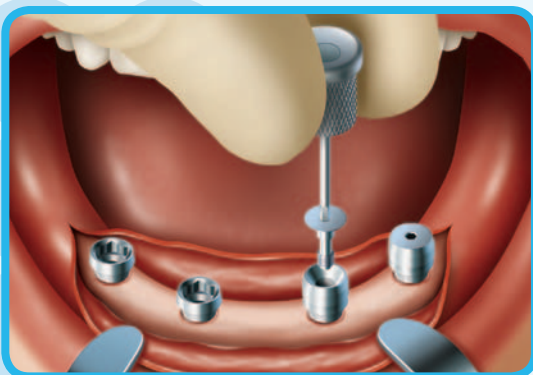
SELECTING METHOD OF IMPLANT CLOSURE

Assess the height of the surrounding soft tissue.

In areas of thin soft tissue, the implant top will be sealed with the supplied Surgical Cover Screw only.

Add the supplied Implant Extender to the implant prior to placement of the Surgical Cover Screw in areas which require additional vertical height. The addition of the extender will add 2mmL of height to the implant top.

For the 4.5mmD implant platform an optional 5.1mmD flared Surgical Cover Screw can be used in cases where there is edematous tissue.



DELIVERING THE HEALING COMPONENTS

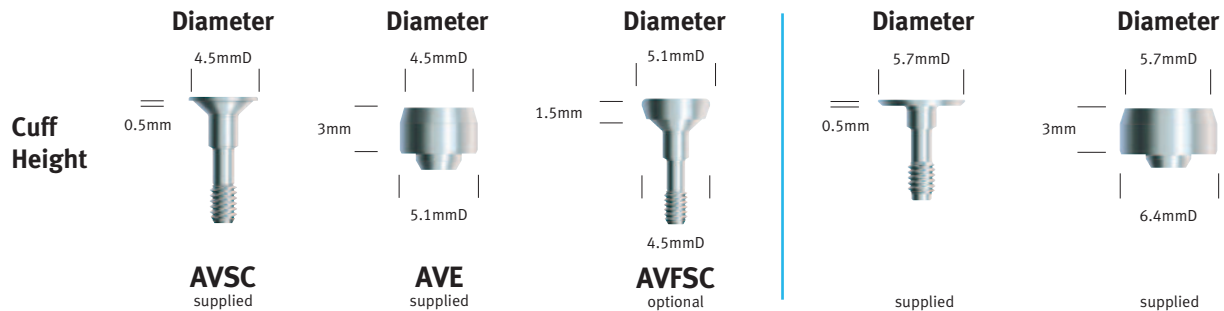
Irrigate the surgical site with sterile water and then suction, ensuring the implants internal chamber is clear of bone and tissue debris and/or blood.

Use the 1.25mmD Hex Driver with GemLock retention [HXGR1.25, HXLGR1.25] to deliver the Implant Extender and/or Surgical Cover Screw to the implant.

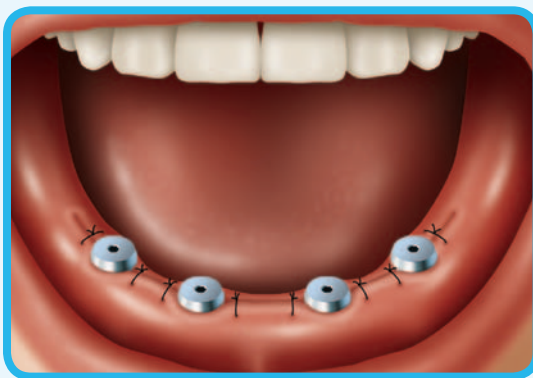
Gently thread the screw into the implant ensuring proper thread engagement between the two components. Use the 1.25mmD Hex Driver with GemLock retention [HXGR1.25, HXLGR1.25] and tighten using finger pressure only. The Surgical Cover Screw will fit flush with the top of the implant or Implant Extender.

HEALING PHASE

HEALING COMPONENTS FOR ADVENT IMPLANTS WITH 4.5MM AND 5.7MM PLATFORM DIAMETERS



Note: AdVent Implants with a 5.7mmD platform utilize *Tapered Screw-Vent* healing components for the 5.7mmD platform.

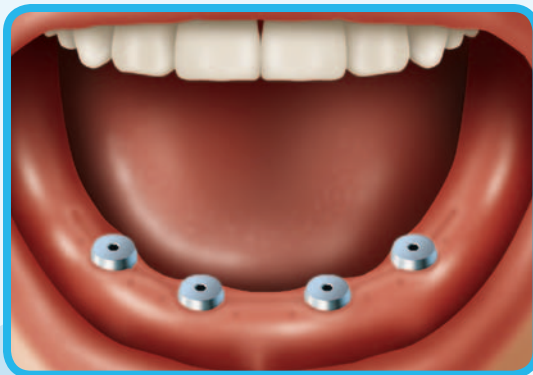


SUTURING THE SOFT TISSUE

Follow standard procedures for one-stage implant placement.

Carefully replace the soft tissue around the Implant Extenders and/or Surgical Cover Screws. Use suture material of choice and suture with one or more of the suture methodologies available (interrupted sutures shown).

Instruct the patient to follow post-surgical maintenance and hygiene. Provide a provisional prosthesis that is designed to prevent any premature loading on the implants. If an immediate prosthesis is planned, follow steps indicated in the *Tapered Screw-Vent and AdVent Implant Restorative Manual*, P/N 4941.



REMOVING THE SUTURES

Remove sutures after the required soft tissue healing period.



REMOVING THE HEALING COMPONENTS

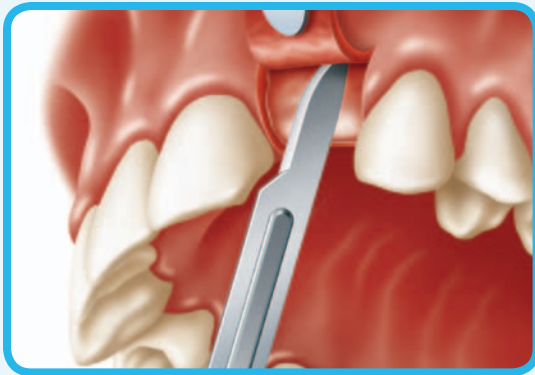
Use the 1.25mmD Hex Driver with *GemLock* retention [HXGR1.25, HXLGR1.25] to remove the healing components after a satisfactory soft and hard tissue healing period, to be determined on a case by case basis.

The implants are now ready for the restorative phase of the implant procedure.

Remove the Surgical Cover Screw and Implant Extender (if placed), prior to restorative procedures.

Refer to the *Tapered Screw-Vent and AdVent Restorative Manual*, P/N 4941, for further restorative instructions.

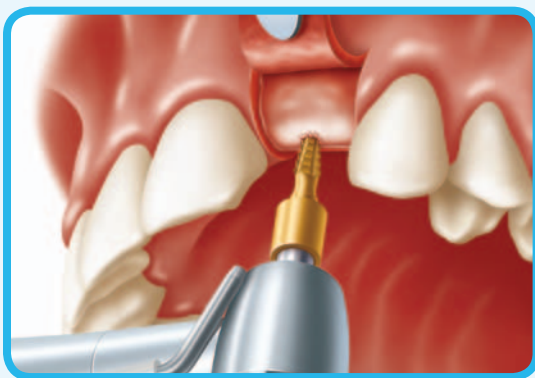
INITIAL SITE PREPARATION – ALL DIAMETERS



ACCESSING THE IMPLANT SITE

A conventional flap is recommended for better visualization of the osseous morphology.

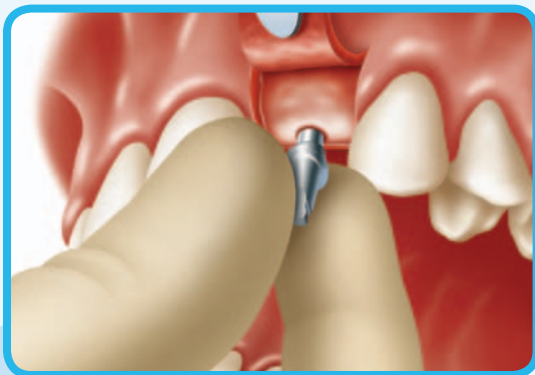
Note: Flapless surgery is only recommended when adequate bone quantity and quality have been established through appropriate diagnostic procedures.



INITIATING THE OSTEOTOMY

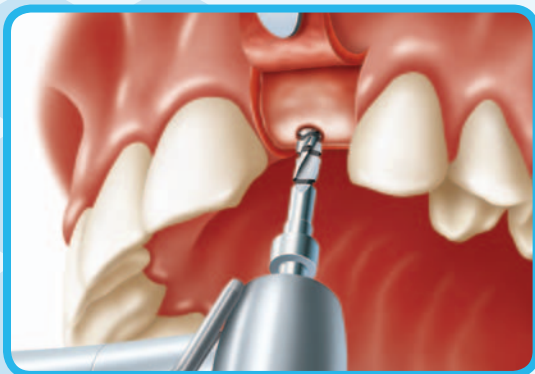
The 2.1/1.6mmD Tapered Pilot Drill [0201, 0201DSN] is used to initiate the osteotomy. The drill's aggressive cutting geometry allows it to function well in dense cortical bone. Care must be taken to ensure that the drill does not over-prepare the osteotomy to a greater depth than desired.

Note: The 0201DSN Tapered Pilot Drill is compatible with the appropriately-sized *Zimmer* Drill Stops.



VERIFYING POSITION AND ANGULATION

The Surgical Try-in replicates the exact geometry of the implant's prosthetic portion. It is placed in the osteotomy to verify position and angulation. A radiograph may be taken to evaluate the osteotomy's proximity to adjacent anatomic structures. Preliminary decisions on size, angulated versus straight, and one-piece versus two-piece implant may be determined at this point.



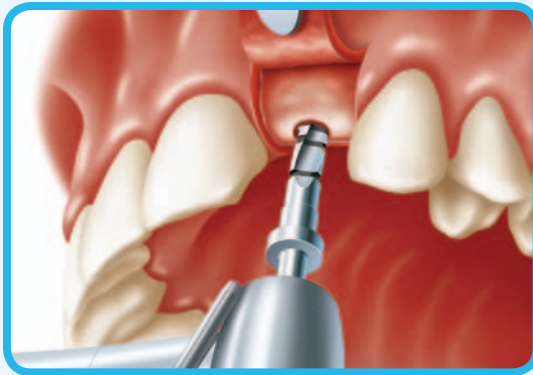
DRILLING THE OSTEOTOMY – 2.3mmD DRILL

Use the 2.3mmD drill to create an intermediate hole to the depth of the implant to be used.

To place a 3.0mmD *Zimmer* One-Piece Implant, proceed to page 62.

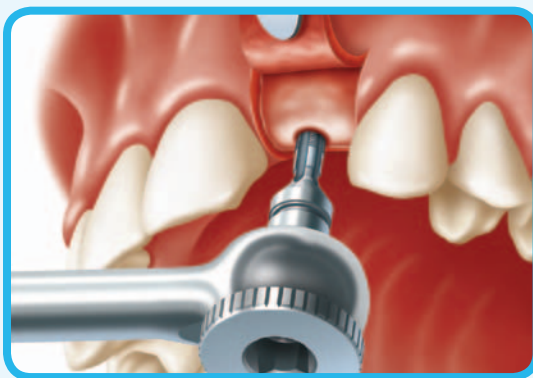
To place a 3.7mmD or 4.7mmD *Zimmer* One-Piece Implant, proceed to page 64.

3.0mmD IMPLANT PROCEDURE AND PLACEMENT



DRILLING THE OSTEOTOMY – 2.8/2.4mmD DRILL

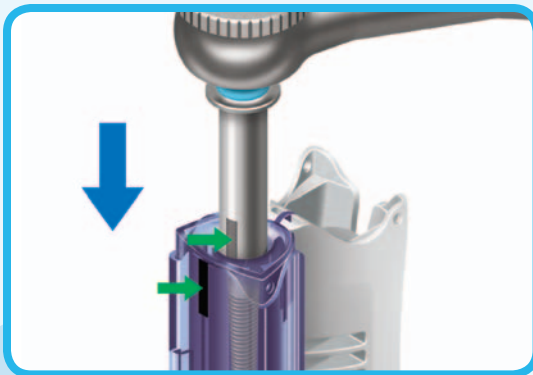
The osteotomy is widened using the 2.8/2.4mmD drill.



OPTIONAL TAPPING OF THE OSTEOTOMY

The Bone Tap is recommended in sites where dense bone (D1-D2) is present. Tap in a clockwise direction at a speed of 15-30 rpm or less. Remove the tap by reversing the handpiece and unthreading at the same speed or less.

To use the handpiece with the Bone Tap or driver, insert the 2.5mm GemLock Hex Drill [RHD2.5] into the handpiece and insert it into the driver or Bone Tap.

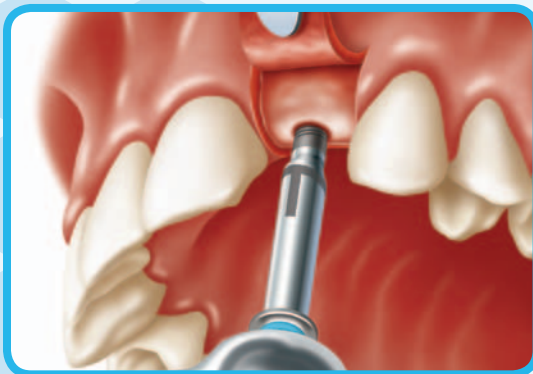


PICKING UP THE IMPLANT

The touch-free packaging allows the implant to be transferred from the package to the patient using the driver and ratchet or handpiece. For detailed instructions see the “Packaging Instructions for Use” on page 75.

The 3.0mmD Implant Driver [ZOPDRS or ZOPDRA] engages the implant externally and has a vertical line to assist with aligning the Driver in the correct position. Ensure the vertical line on the Driver is lined up with the vertical line on the inner vial.

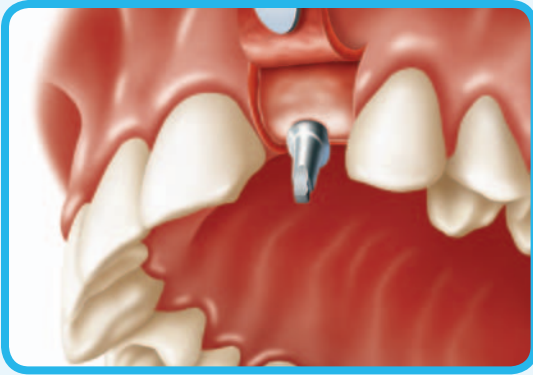
Push down gently to seat the implant into the Driver.



INSERTING THE IMPLANT

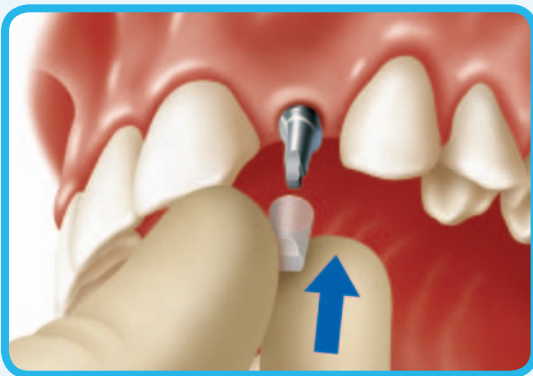
Using the ratchet or the handpiece, thread the implant into the osteotomy (15-30 rpm or less). The seating torque should be set at 35 Ncm.

3.0mmD IMPLANT PROCEDURE AND PLACEMENT



POSITIONING THE ZIMMER ONE-PIECE 3.0mmD IMPLANT

Ideal positioning of the *Zimmer One-Piece Implant* results in the top of the implant portion being as close as possible to the crestal bone level, with the lower aspect of the prosthetic margin positioned buccolabially. The distance between the top of the implant portion and the lower buccolabial margin is 1.2mm, and the implant also seats 1.2mm per revolution. Therefore, this distance can be used as a reference to determine whether an additional implant revolution can be made. Utilize the vertical line on the driver to indicate buccolabial placement of the lower margin.



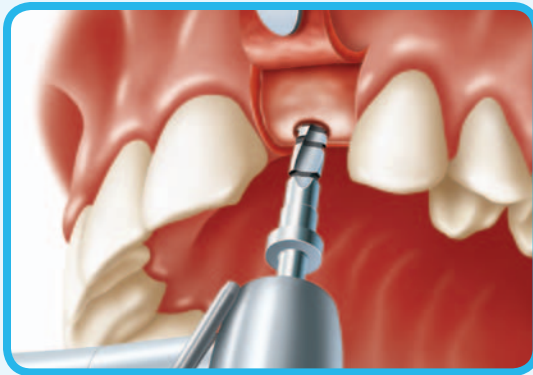
PREPARING THE IMPLANT FOR THE HEALING PHASE

Place the Contour Healing Cap on the *Zimmer One-Piece Implant*. The healing cap can be cemented into place at the time of surgery. Alternatively, cement an immediate provisional crown into place.

After an appropriate implant healing period, the implant will be ready for the restorative phase of the procedure. Refer to the *Zimmer One-Piece Implant System Surgical and Restorative Manual*, P/N 7458, for further restorative instructions.

Note: Titanium residues, vibration and heat associated with preparing the abutment may have possible adverse effects on the implant or adjacent bone. If excessive inter-oral preparation is required, use of a two-piece implant is recommended.

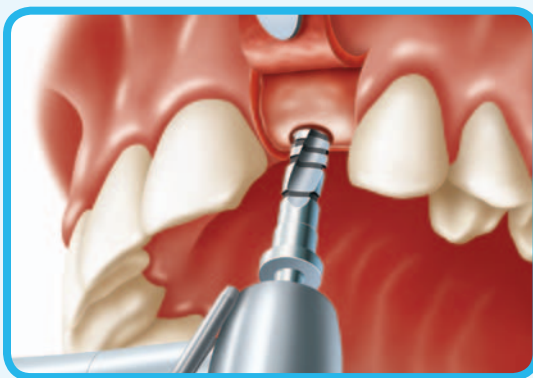
3.7mmD AND 4.7mmD IMPLANT PROCEDURE AND PLACEMENT



WIDENING THE OSTEOTOMY

For 3.7mmD *Zimmer* One-Piece Implants:
The osteotomy is widened using the 2.8mmD drill.

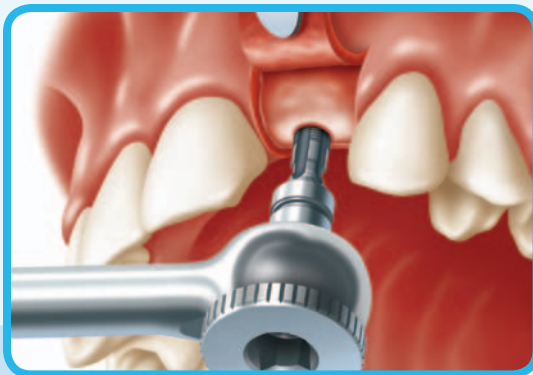
For 4.7mmD *Zimmer* One-Piece Implants:
The osteotomy is widened using the 3.4/2.8mmD drill.



FINALIZING THE OSTEOTOMY

For 3.7mmD *Zimmer* One-Piece Implants:
Use the 3.4/2.8mmD drill as the final for the 3.7mmD *Zimmer* One-Piece Implant.

For 4.7mmD *Zimmer* One-Piece Implants:
In soft bone, use the 3.8mmD drill as the final. In dense bone, use the 4.4/3.8mmD drill instead as the final to widen the osteotomy further.



OPTIONAL TAPPING OF THE OSTEOTOMY

The Bone Tap is recommended in sites where dense bone (D1-D2) is present. Tap in a clockwise direction at a speed of 15-30 rpm or less. Remove the tap by reversing the handpiece and unthreading at the same speed or less.

To use the handpiece with the Bone Tap or driver, insert the 2.5mm *GemLock* Hex Drill [RHD2.5] into the handpiece and insert it into the driver or Bone Tap.



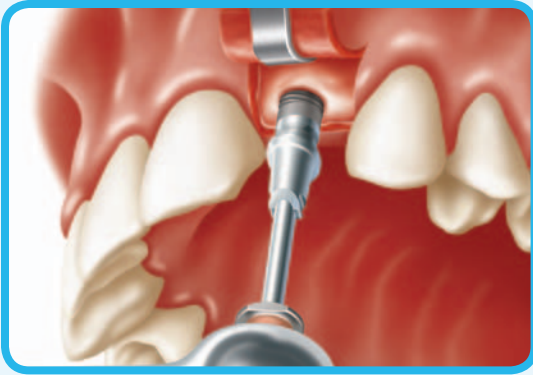
PICKING UP THE IMPLANT

The touch-free packaging allows the implant to be transferred from the package to the patient using the driver [ZOPDRH or ZOPDRT] and *GemLock* Retaining Square Ratchet [RSR] or handpiece. For detailed instructions see the "Packaging Instructions for Use" on page 75.

Line up the flat side of the driver to the lower prosthetic margin as the implant is retrieved from the vial. This step will aid in positioning the lower prosthetic margin to the buccolabial aspect for the implant's final positioning.

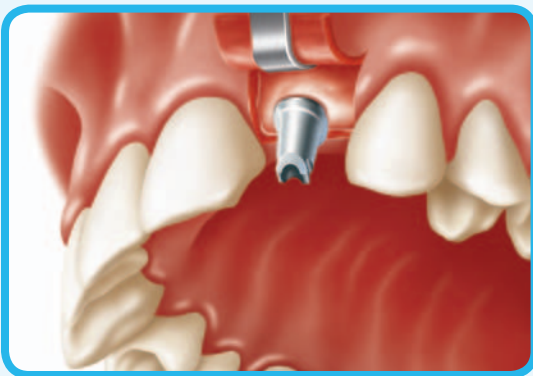
The Implant Driver [ZOPDRT, ZOPDRH] engages the implant internally. Push down gently to seat the driver into the implant. Make sure the driver is fully engaged and bottomed in the hexagon socket before applying torque.

3.7mmD AND 4.7mmD IMPLANT PROCEDURE AND PLACEMENT



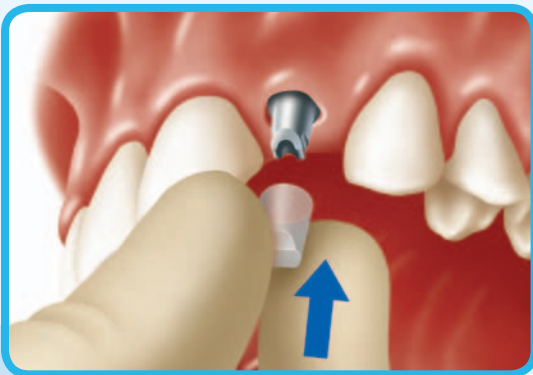
INSERTING THE IMPLANT

Using the ratchet or handpiece, thread the implant into the osteotomy (15-30 rpm or less).



POSITIONING THE ZIMMER ONE-PIECE 3.7mmD AND 4.7mmD IMPLANT

Ideal positioning of the *Zimmer One-Piece Implant* results in the top of the implant portion being as close as possible to the crestal bone level, with the lower aspect of the prosthetic margin positioned buccolabially. The distance between the top of the implant portion and the lower buccolabial margin is 1.2mm, and the implant also seats 1.2mm per revolution. Therefore, this distance can be used as a reference to determine whether an additional implant revolution can be made. If the flat on the 3.7mmD or 4.7mmD Driver was lined up with the lower prosthetic margin when the implant was retrieved from the vial, the flat on the driver will indicate the buccolabial aspect for the implant's final placement.



PREPARING THE IMPLANT FOR THE HEALING PHASE

Place the Contour Healing Cap on the *Zimmer One-Piece Implant*. The healing cap can be cemented into place at the time of surgery. Alternatively, cement an immediate provisional crown into place.

After an appropriate implant healing period, the implant will be ready for the restorative phase of the procedure. Refer to the *Zimmer One-Piece Implant System Surgical and Restorative Manual*, P/N 7458, for further restorative instructions.

Note: Titanium residues, vibration and heat associated with preparing the abutment may have possible adverse effects on the implant or adjacent bone. If excessive inter-oral preparation is required, use of a two-piece implant is recommended.

OVERVIEW

Zimmer Guided Surgery Instrumentation is compatible with industry-leading case planning software and surgical guide manufacturers. Combined with a third-party surgical guide, it enables actualization from the software to the mouth, helping to increase predictability, accuracy, and reduce the risk of surgical and prosthetic complications.

With the benefits of digital dentistry and 3D treatment planning, Zimmer Guided Surgery Instrumentation will aid in more precise implant site preparation for the *Tapered Screw-Vent* Implant System, including *Trabecular Metal*, *Tapered Screw-Vent*, *Zimmer One-Piece* and *AdVent* implants.

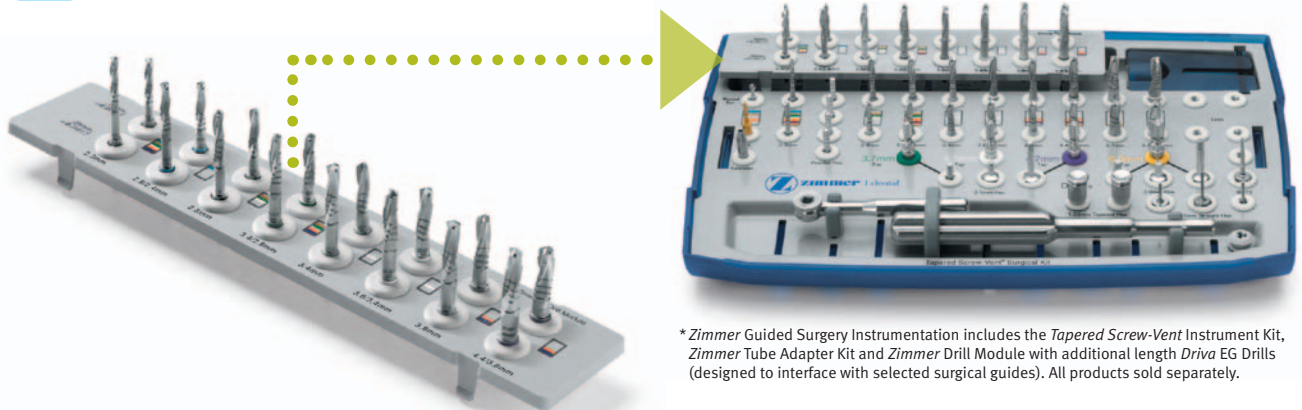
Zimmer Guided Surgery Instrumentation is utilized with the *Tapered Screw-Vent* Surgical Kit, thereby requiring minimal additional instrumentation.



GUIDED SURGERY MODULE

The *Zimmer Drill Module* with *Dríva* EG Drills can be easily inserted into an existing *Tapered Screw-Vent* Surgical Kit to accommodate both traditional and guided procedures [Figure 1].

Fig. 1



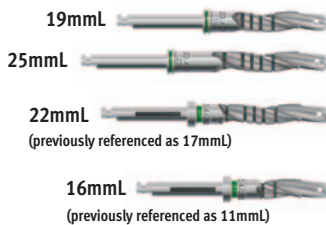
* *Zimmer Guided Surgery Instrumentation* includes the *Tapered Screw-Vent Instrument Kit*, *Zimmer Tube Adapter Kit* and *Zimmer Drill Module* with additional length *Dríva* EG Drills (designed to interface with selected surgical guides). All products sold separately.

The *Zimmer Drill Module* with *Dríva* EG Drills can be easily inserted into an existing *Tapered Screw-Vent* Surgical Kit. Please note that all four lengths of *Dríva* drills are required to perform *Zimmer Guided Surgery* procedures [Figure 1].

SURGICAL DRILLS

Updated *Dríva* Drills and *Zimmer Drill Module* with additional length *Dríva* EG Drills are required to interface with surgical guides and provide depth control. Please note that all four lengths of *Dríva* drills are required to perform *Zimmer Guided Surgery* procedures.

Fig. 2



Various drill lengths and placement in kit.



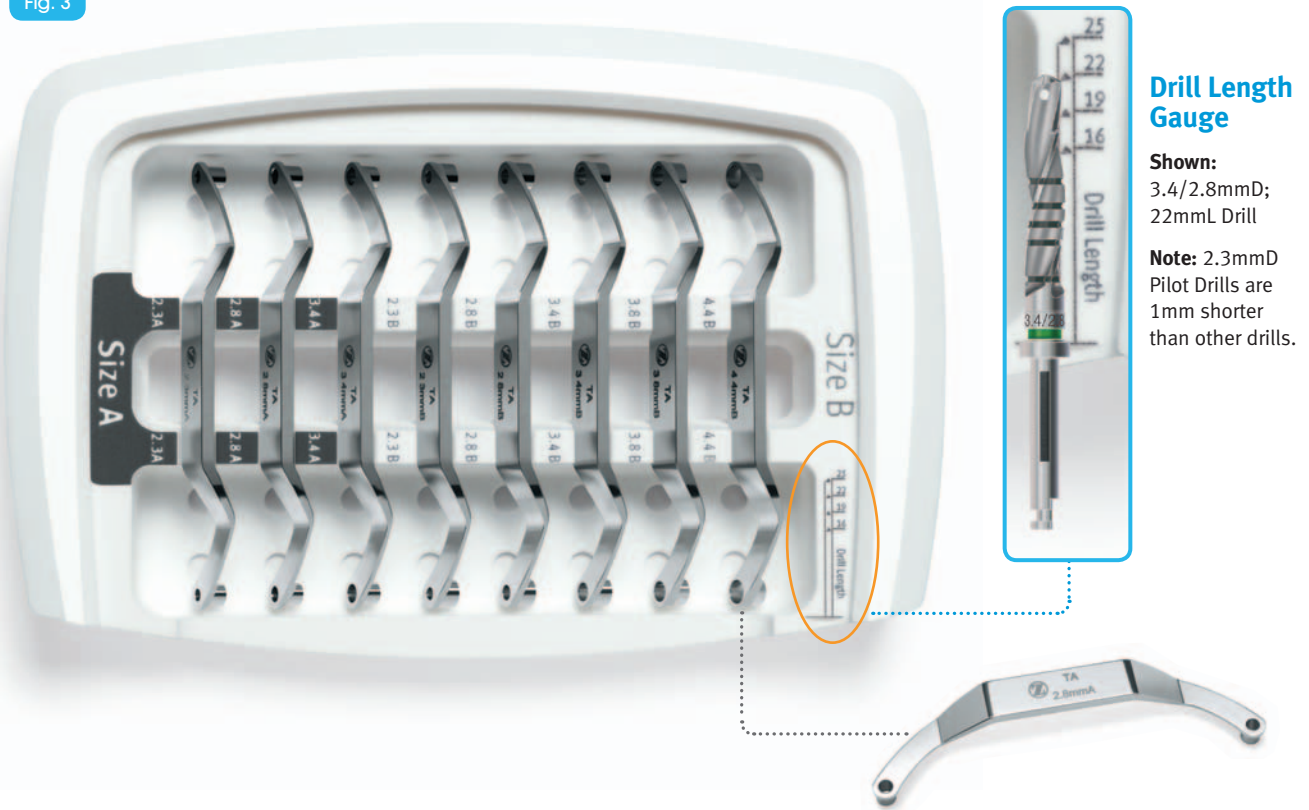
Tapered Screw-Vent® Surgical Kit

Note: The design of the *Dríva* Drills included in the *Zimmer Instrument Kit System* have been updated to support compatibility with *Zimmer's Guided Surgery Instrumentation*. As shown above, the updated 16mm and 22mm drills can be identified by the addition of black vertical lines. Ensure that you have the updated 16mm and 22mm *Dríva* Drills prior to utilizing *Zimmer's Guided Surgery instrumentation*, as only the updated *Dríva* Drills are compatible. Note that all 19mm and 25mm drills are compatible with *Zimmer's Guided Surgery Instrumentation*.

ZIMMER TUBE ADAPTER KIT

Tube Adapters [Figure 3] fit in the tubes located inside the surgical guide to orient drills and provide positional and angulation control. Use Tube Adapter Diameter A when preparing the osteotomy for 3.0mm or 3.7mm diameter implants, and Tube Adapter Diameter B when preparing the osteotomy for 4.1mm or 4.7mm diameter implants. Tube Adapters may be used on the right or left side of the patient's oral cavity as both ends of each Adapter have identical-diameter holes.

Fig. 3



Drill Length Gauge

Shown:
3.4/2.8mmD;
22mmL Drill

Note: 2.3mmD
Pilot Drills are
1mm shorter
than other drills.

Driva Drills facilitate internal irrigation through the surgical guide, thus limiting frictional heat and reducing the risk of osteonecrotic changes as a result of overheating³³⁻³⁵ [Figure 4].



Fig. 4

SURGICAL TECHNIQUE

Select Drills and Tube Adapters following the protocol provided by the surgical guide manufacturer [Figure 5]. The predetermined drilling depth is achieved by the combination of custom guide height and appropriate drill length selection, indicated by the guide manufacturer. Drill flange will stop on the top of the Tube Adapter when a desired depth is achieved.

NOTE: VERIFY DRILL LENGTH WITH THE DRILL LENGTH GAUGE ON THE TUBE ADAPTER KIT [FIGURE 3] ON PREVIOUS PAGE.

EXAMPLE BELOW: SURGICAL PROTOCOL EXAMPLE FOR A TOOTH-SUPPORTED GUIDE: THREE ZIMMER DENTAL IMPLANTS IN MANDIBLE (TOOTH #23, #25, #27).

Fig. 5

SAMPLE SURGICAL PROTOCOL FOR ZIMMER GUIDED SURGERY INSTRUMENTATION

1	Tooth Number	23	25	27
	Implant Information			
2	Implant part number	TSVB16	TSVB11	TSVWB13
3	Implant diameter (mm)	3.7	3.7	4.7
4	Implant length (mm)	16	11.5	13
5	Depth control	Yes	Yes	Yes
	Surgical Sequence			
6	Tube Adapter	2.3 A	2.3 A	2.3 B
7	Drill	2.3 (22mm)	2.3 (19mm)	2.3 (19mm)
8	Tube Adapter	2.8 A	2.8 A	3.4 B
9	Drill	2.8 (22mm)	2.8 (19mm)	3.4/2.8 (19mm)
10	Tube Adapter	3.4 A	3.4 A	3.8 B
11	Drill	3.4/2.8 (22mm)	3.4/2.8 (19mm)	3.8 (19mm)
12	Tube Adapter	•	•	4.4 B
13	Drill	•	•	4.4/3.8 (19mm)

Note: The instrument selection protocol and appearance may differ depending on the case planning software. For detailed information about location of the instruments in the surgical kits, please reference the *Zimmer Guided Surgery Reference Guide*, P/N 1392.

For detailed *Zimmer Guided Surgery* technique information, please reference the *Zimmer Guided Surgery Technique Guide*, P/N 1349. For detailed surgical guide instructions for use please contact your software and/or surgical guide manufacturer.

Sample Surgical Protocol for Zimmer Guided Surgery Instrumentation



Order Details

Order Id - Patient Name: _____

Client Order Reference: _____

Contact Person: _____

Shipment Date: _____

Quality Control

Initials: _____

Signature: _____

	Bone	Mucosa	Tooth
Maxilla			
Mandible			X

For all surgical technique details please reference the Zimmer® Guided Surgery Technique Guide and the Reference Guide.

NOTE: Verify drill length with the Drill Length Gauge on the Tube Adapter Kit (image to the right). The 2.3mm Drills are 1mm shorter than all the other drills except for the 2.5/1.6mm Pilot Drill.

Color-coding corresponds with the implant color-coding and the Zimmer® Instrument Kit System. The protocol provided is for both bone. For soft bone, use the final Step Drill (per the Reference Guide). The selection depth created by the 2.5/1.6mm Pilot Drill can range from 1mm for a bone-supported guide to approximately 4mm for a mucosa-supported guide.

After creation of the color-coding, remove the surgical guide and follow the standard implant placement guidelines.

The Zimmer Guided Surgery protocol listed below is for this patient specific case only and is based on the implant diameters and lengths in the submitted case plan. Changes to the surgical plan may require changes in implant diameters and lengths resulting in a change to the surgical protocol and surgical guide.

Surgical Protocol for Zimmer Guided Surgery

1	Tooth Number	23	25	27
	Implant Information			
2	Implant part number	TSVB16	TSVB11	TSVWB13
3	Implant diameter (mm)	3.7	3.7	4.7
4	Implant length (mm)	16	11.5	13
5	Depth Control	Yes	Yes	Yes
	Surgical Sequence			
6	Tube Adapter	2.3 A	2.3 A	2.3 B
7	Drill	2.3 (22mm)	2.3 (19mm)	2.3 (19mm)
8	Tube Adapter	2.8 A	2.8 A	3.4 B
9	Drill	2.8 (22mm)	2.8 (19mm)	3.4/2.8 (19mm)
10	Tube Adapter	3.4 A	3.4 A	3.8 B
11	Drill	3.4/2.8 (22mm)	3.4/2.8 (19mm)	3.8 (19)
12	Tube Adapter	-	-	4.4 B
13	Drill	-	-	4.4/3.8 (19mm)

If you have any additional questions or require clarification on case planning or patient specific guide, please contact Materialize Dental. For all other inquiries, please contact Zimmer Dental.

2023 Rev. 0010
©2023 Zimmer Dental Inc. All rights reserved.



TREATMENT PLANNING

Clinician performs the clinical exam and takes patient records and diagnostics. Overall restorative treatment plan for the desired restorative outcome is developed in conjunction with the implant team. If required, patient is referred to the surgical specialist for further evaluation.



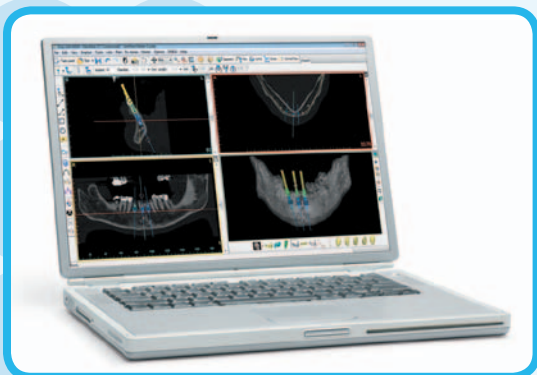
SCAN PROTHESIS

Dental laboratory or clinician fabricates a scan prosthesis — generally a radiopaque duplicate of the provisional teeth set-up or patient's existing denture — for visibility of the desired tooth location in CT images and selected case planning software.



CT SCAN

Patient undergoes CT scan (wearing the scan prosthesis), according to the software supplier's general scanning instructions — including patient preparation, positioning, image reconstruction, and scanning parameters.

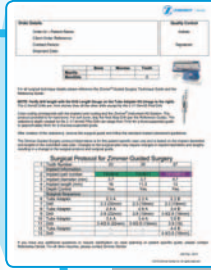


SURICAL CASE PLANNING

The CT scan data is converted into a format that allows it to be utilized by the selected case planning software, or is imported directly. The case is then planned in the treatment planning software.

Shown: *SimPlant*® Software by Materialise Dental NV.

SURGICAL TECHNIQUE



SURGICAL GUIDE & PROTOCOL ARRIVES

The software supplier or dental laboratory fabricates the case-specific surgical guide compatible with *Zimmer* Guided Surgery Instrumentation. The guide manufacturer delivers the surgical guide, along with the surgical protocol for each *Trabecular Metal*, *Tapered Screw-Vent*, *Zimmer One-Piece* or *AdVent* Implant site preparation.

	Bone	Mucosa	Tooth
Maxilla			
Mandible			X



For all surgical technique details please reference the *Zimmer*® Guided Surgery Technique Guide and the Reference Guide.

NOTE: Verify drill length with the Drill Length Gauge on the Tube Adapter Kit (image to the right). The 2.3mmD Drills are 1mm shorter than all the other drills except for the 2.1/1.6mmD Pilot Drill.

Color-coding corresponds with the implant color-coding and the *Zimmer*® Instrument Kit System. The protocol provided is for hard bone. For soft bone, skip the final Step Drill (per the Reference Guide). The osteotomy depth created by the 2.1/1.6mmD Pilot Drill can range from 7mm for a bone-supported guide to approximately 4mm for a mucosa-supported guide.

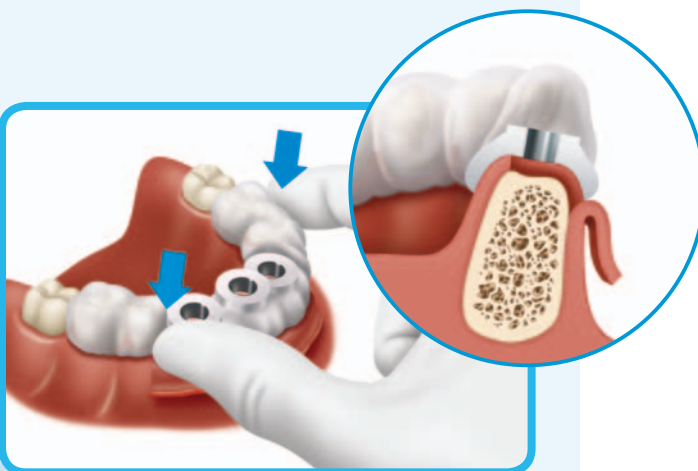
After creation of the osteotomy, remove the surgical guide and follow the standard implant placement guidelines.

The *Zimmer* Guided Surgery protocol listed below is for this patient specific case only and is based on the implant diameters and lengths in the submitted case plan. Changes to the surgical plan may require changes in implant diameters and lengths resulting in a change to the surgical protocol and surgical guide.

Surgical Protocol for <i>Zimmer</i> Guided Surgery				
1	Tooth Number	23	25	27
Implant Information				
2	Implant part number	TSV816	TSV811	TSV811
3	Implant diameter (mm)	3.7	3.7	4.7
4	Implant length (mm)	16	11.5	13
5	Depth Control	Yes	Yes	Yes
Surgical Sequence				
6	Tube Adapter	2.3 A	2.3 A	2.3 B

SURGICAL PROTOCOL SUMMARY

Surgical protocol for *Zimmer* Guided Surgery Instrumentation provides detailed information regarding proper Drill sequence and Tube Adapter selection for the surgical preparation of each implant site.



SURGICAL GUIDE PLACEMENT

The tooth-, mucosa-, or bone-supported surgical guide is fixed to the surgical site. Commercially available fixation pins may be utilized for a mucosa-supported guide.

Shown: A tooth-supported surgical guide with elevated flap.



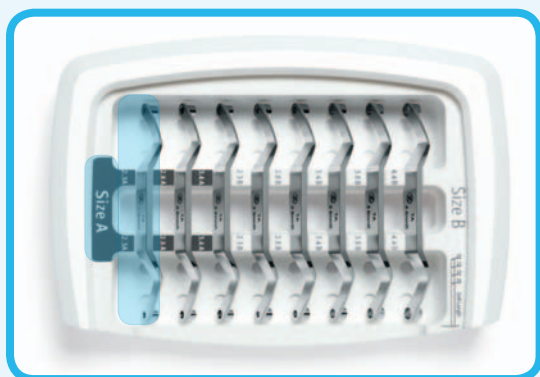
GUIDED SURGERY INSTRUMENTATION

Referencing the case-specific surgical protocol provided with the surgical guide, follow the sequence of Tube Adapters and Surgical Drills to prepare the implant osteotomy.

The Tube Adapter fits inside the titanium tube insert in the surgical guide. Tube Adapters — used in conjunction with the Drills and length-specific surgical guides — provide positional, angulation and depth control, and are labeled for easy identification. Tube Adapters can be used on the patient’s left- or right-hand side as the holes on both sides are identical in diameter.

Steps 9-14 detail the surgical sequence for the example case shown in the surgical protocol on page 69: an osteotomy for a 3.7mmD x 16mmL *Tapered Screw-Vent* Implant in tooth location #23, in dense bone (a dense bone protocol should be followed).

Note: The protocol provided is for dense bone. For soft bone, skip the final Step Drill.



TUBE ADAPTER SELECTION

Following the surgical guide protocol, select the initial Tube Adapter 2.3 A (2.3mmD; size A) from the Tube Adapter Kit. Place the Tube Adapter into the guide tube on the most convenient side.



DRILL SELECTION

Select the initial Drill from the protocol – 2.3 (22mm), (2.3mmD; 22mmL). Verify Drill length of 22mm with the Drill Length Gauge on the Tube Adapter Kit

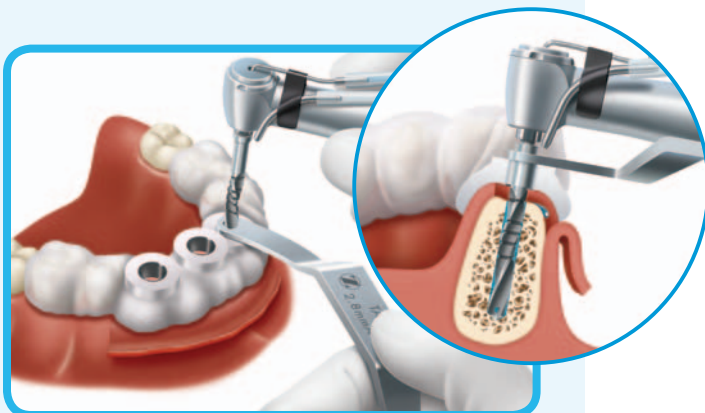
Shown: 3.4/2.8mmD; 22mmL Drill.

Note: 2.3mmD Pilot Drills are 1mm shorter than other Drills.

SURGICAL TECHNIQUE

**INITIATING THE OSTEOTOMY**

Drill to initiate an osteotomy through the Tube Adapter until the Drill flange stops on top of the Tube Adapter. The predetermined drilling depth is achieved by the combination of custom guide height and appropriate Drill selection, indicated in the guide manufacturer's protocol.

**EXPANDING THE OSTEOTOMY**

Remove the Tube Adapter 2.3 A and place the next Tube Adapter 2.8 A into the guide tube opening. Use the next Drill in the sequence, 2.8 (22mm), to expand the osteotomy through the Tube Adapter until the Drill flange stops on top. Verify Drill length of 22mm with the Drill Length Gauge on the Tube Adapter Kit.

**EXPANDING THE OSTEOTOMY (CONTINUED)**

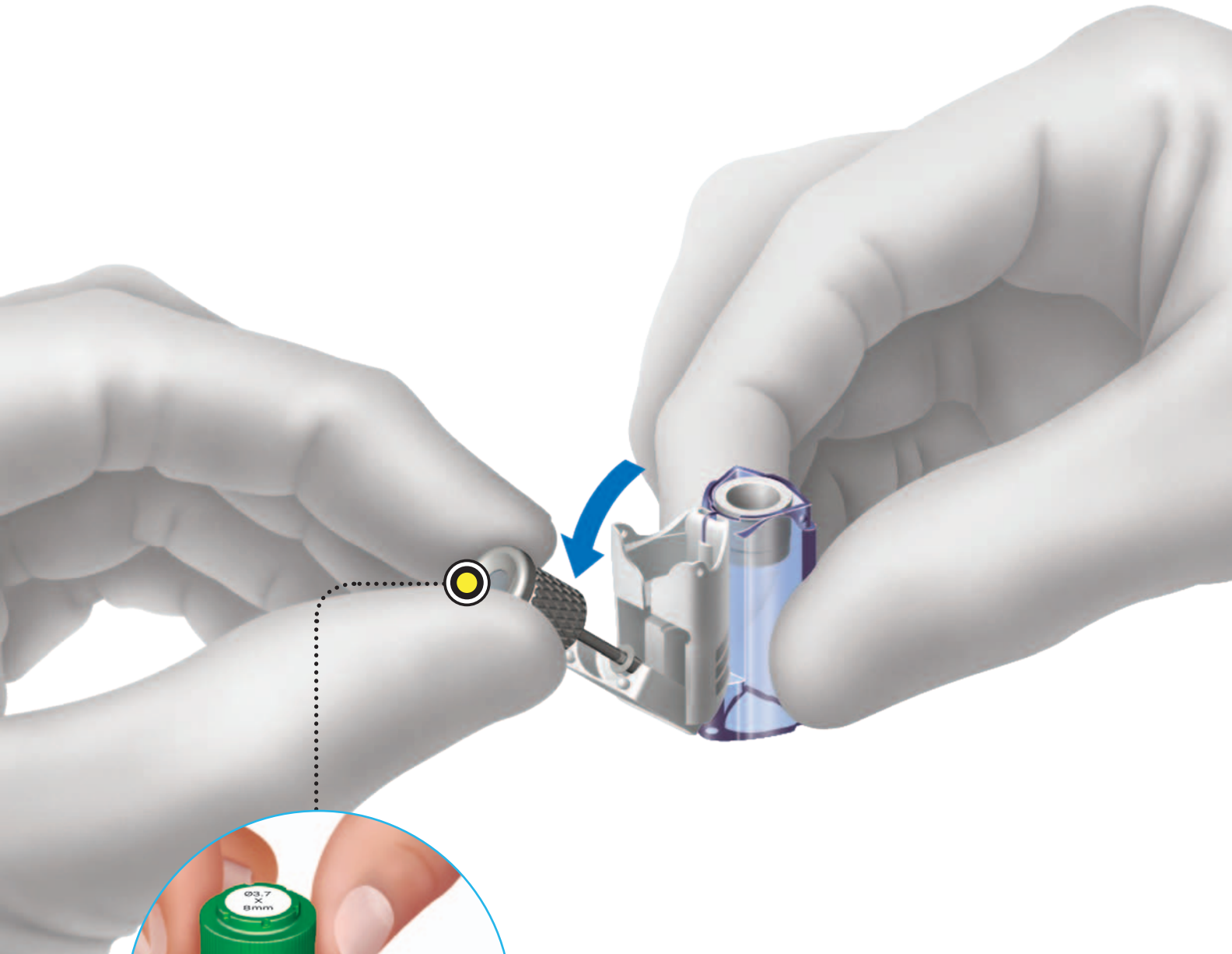
Remove the Tube Adapter 2.8 A and place the next Tube Adapter 3.4 A into the guide tube opening. Select the next Drill in the sequence, 3.4/2.8 (22mm). Following Drill length verification with the Drill Length Gauge, expand the osteotomy through the Tube Adapter until the Drill flange stops on top.

**PLACING THE IMPLANT**

Remove the surgical guide and follow standard implant placement guidelines.

Optional: Use of the 3.7mmD Cortical Bone Tap may be required in dense bone.

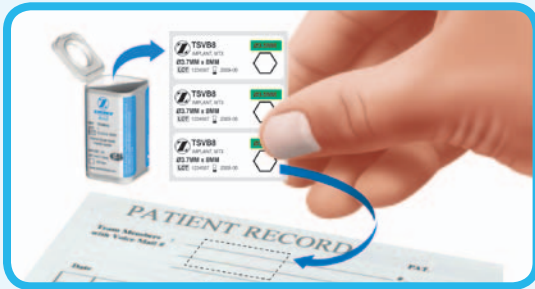
PACKAGING INSTRUCTIONS FOR USE



TRABECULAR METAL, TAPERED SCREW-VENT AND ADVENT IMPLANTS



Remove the implant outer vial from the box.



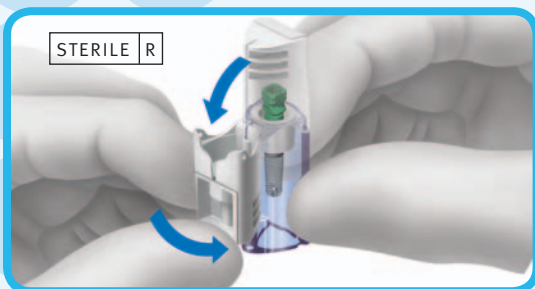
Locate the patient record labels, indicating product description and lot number, and adhere to the patient's chart.



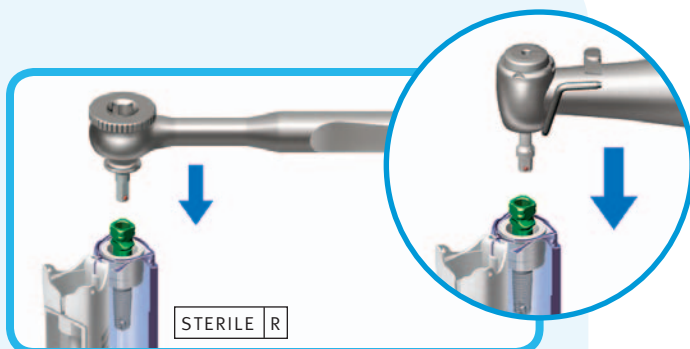
Open the outer vial to break the seal.



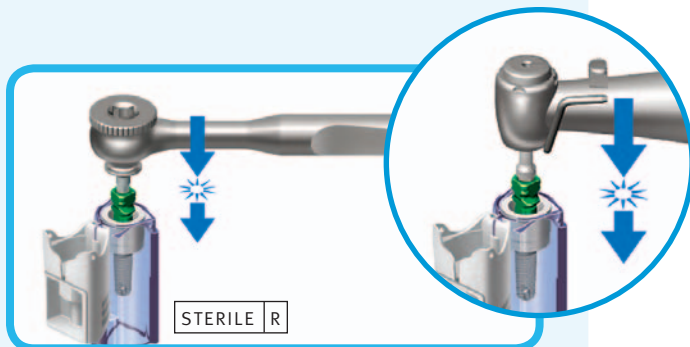
Drop the sterile inner vial and contents onto a sterile field.



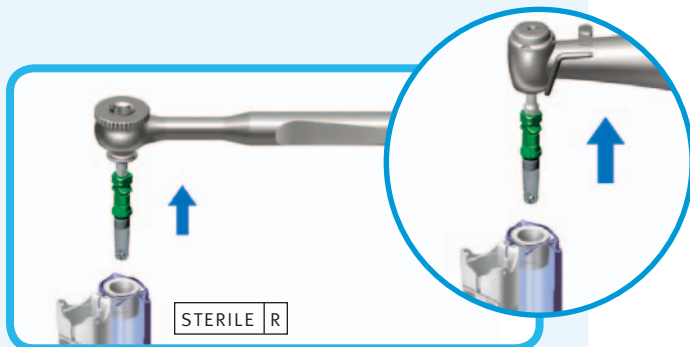
Flip the white top of the inner vial open by pressing on the flat side with access hole. Press the top to the inner vial body to lock in place.



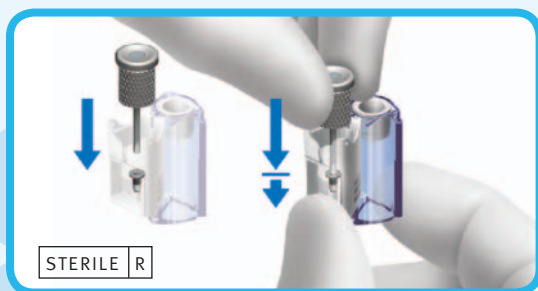
Place the appropriate insertion instrument over the end of the fixture mount.



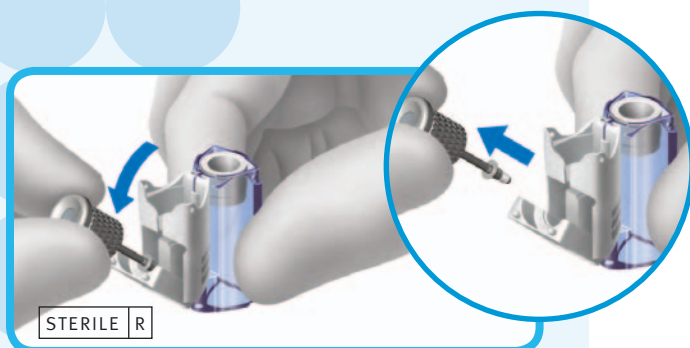
Engage the fixture mount with the insertion instrument.



Lift the implant from the inner vial and carry it to the reception site. Initiate the implant into the osteotomy and complete seating with the appropriate instruments. After the implant is fully seated, remove the fixture mount with the 1.25mmD Hex Driver with *GemLock* retention [[HXGR1.25](#), [HXLGR1.25](#)].



Locate the surgical cover screw in the cap of the inner vial. Using the 1.25mmD Hex Driver with *GemLock* retention [[HXGR1.25](#), [HXLGR1.25](#)], engage the cover screw.



Engage the cover screw with the 1.25mmD Hex Driver with *GemLock* retention [[HXGR1.25](#), [HXLGR1.25](#)] and push down to open door. The surgical screw will be engaged.

1. Lekholm U, Zarb GA. Patient selection and preparation. In Branemark P-I, Zarb GA, Albrektsson T, editors: Tissue integrated prostheses: osseointegration in clinical dentistry. *Quintessence*, Chicago, 1985.11-76.
2. Le Gall, MG. Localized sinus elevation and osteocompression with single-stage tapered dental implants: technical note. *Int J Oral Maxillofac Implants*. 2004 May-Jun;19(3):431-7.
3. Wigfield C, Robertson J, Gill S, Nelson R. Clinical experience with porous tantalum cervical interbody implants in a prospective randomized controlled trial. *Br J Neurosurg*. 2003;17(5):418-425.
4. Unger AS, Lewis RJ, Gruen T. Evaluation of a porous tantalum uncemented acetabular cup in revision total hip arthroplasty. Clinical and radiological results of 60 hips. *J Arthroplasty*. 2005;20(8):1002-1009.
5. Bobyn JD, Stackpool GJ, Hacking SA, Tanzer M, Krygier JJ. Characteristics of bone ingrowth and interface mechanics of a new porous tantalum biomaterial. *J Bone Joint Surg Br*. 1999; 81:907-914.
6. Cohen R. A porous tantalum trabecular metal: basic science. *Am J Orthop*. 2002;31(4):216-217.
7. Data on file.
8. Data on file.
9. Data on file.
10. Data on file.
11. Mihalko WM, May TC, Kay JF, Krause WP. Finite element analysis of interface geometry effects on the crestal bone surrounding a dental implant. *Implant Dent*. 1992;1:212-217.
12. Chun HJ, Shin HS, Han CH, Lee SH. Influence of implant abutment type on stress distribution in bone under various loading conditions using finite element analysis. *Int J Oral Maxillofac Implants*. 2006;21:105-202.
13. Williams DF. Titanium as a metal for implantation, part 2: biological properties and clinical applications. *J Med Eng Technol*. 1977 Sep;1(5):266-70.
14. American Society for Testing and Materials Committee on Standards. Designation B 348-94. Standard specification for titanium and titanium alloy bars and billets. *Annual Book of ASTM Standards. Vol. 02.04*. Philadelphia: American Society for Testing and Materials, 1994: 141-146.
15. American Society for Testing and Materials International. Designation F 67-06. Standard specification for unalloyed titanium, for surgical implant applications. 2006.
16. International Organization for Standardization. ISO 5832-2: Implants for surgery – metallic materials - part 2: unalloyed Titanium. 1999. Available online at: <http://www.iso.org>.
17. International Organization for Standardization. ISO 5832-3: Implants for surgery – metallic materials – part 3: wrought titanium 6-aluminum 40-vanadium alloy. 1996. Available online at: <http://www.iso.org>.

18. Bobyn JD. UHMWPE: the good, bad, & ugly. Fixation and bearing surfaces for the next millennium. *Orthop*. 1999;22(9):810-812.
19. Nasser S, Poggie RA. Revision and salvage patellar arthroplasty using a porous tantalum implant. *J Arthroplasty*. 2004;19(5):562-572.
20. Tsao AK, Roberson JR, Christie MJ, Dore DD, Heck DA, Robertson DD, Poggie RA. Biomechanical and clinical evaluations of a porous tantalum implant for the treatment of early-stage osteonecrosis. *J Bone Joint Surg*. 2005;87-A(Suppl 2):22-27.
21. Bobyn JD, Poggie RA, Krygier JJ, Lewallen DF, Hanssen AD, Lewis RJ, Unger AS, O'Keefe TJ, Christie MH, Nasser S, Wood JE, Stulberg SD, Tanzer M. Clinical validation of a structural porous tantalum biomaterial for adult reconstruction. *J Bone Joint Surg*. 2004;86-A(Suppl 2):123-129.
22. Black J. Biological performance of tantalum. *Clin Mater*. 1994;16:167-173.
23. Bellinger DH. Preliminary report on the use of tantalum in maxillofacial and oral surgery. *J Oral Surg*. 1947;5(1):108-122.
24. Burke GL. The corrosion of metals in tissues; and an introduction to tantalum. *Can Med Ass J*. 1940;43(2):125.
25. Matsuno H, Yokoyama A, Watari F, Uo M, Kawasaki T. Biocompatibility and osteogenesis of refractory metal implants, titanium, hafnium, niobium, tantalum, and rhenium. *Biomaterials*. 2001;22:1253-1262.
26. Welldon KJ, Atkins GJ, Howie DW, Findlay DM. Primary human osteoblasts grow into porous tantalum and maintain an osteoblastic phenotype. *J Biomed Mater Res A*. 2008;84(3):691-701.
27. Venable CS, Stuck WG. A general consideration of metals for buried appliances in surgery. *Int Abst Surg*. 1943;66:297-304.
28. Pudenz RH. The use of tantalum clips for hemostasis in neurosurgery. *Surgery*. 1942;12:791-791.
29. Robertson RCL, Peacher WG. The use of tantalum foil in the subdural space. *J Neurosurg*. 1945;2:281-284.
30. Echols DH, Colelough JA. Cranioplasty with tantalum plate. Report of eight cases. *Surgery*. 1945;14:304-314.
31. Linkow LI, Rinaldi AW. Evolution of the Vent-Plant osseointegrated compatible implant system. *Int J Oral Maxillofac Implants*. 1988;3:109-122.
32. Binon PP. The evolution and evaluation of two interference-fit implant interfaces. *Postgraduate Dentistry*. 1996;3:3-13.
33. Lavelle C, Wedgwood D. Effect of internal irrigation on frictional heat generated from bone drilling. *J Oral Surgery*. 1980;38:499-503.
34. Tehemar SH. Factors affecting heat generation during implant site preparation: a review of biologic observations and future considerations. *Intl J Oral Maxillofac Implants*. 1999;14:127-136.
35. Yacker MJ, Klein M. The effect of irrigation on osteotomy depth and bur diameter. *Intl J Oral Maxillofac Implants*. 1996;11:634-638.

For more information about our Products, Regenerative Materials and Educational Opportunities, contact us:

1900 Aston Avenue
Carlsbad, CA 92008-7308
USA

In the U.S. 1 (800) 854-7019
To fax an order 1 (888) 225-2483
Outside the U.S. +1 (760) 929-4300
Australia +61 (0)2 9950 5434 or 1 (800) 241 916
Canada + 1 (905) 567-2073 or 1 (800) 265-0968
China +86 21 22115147

France +33 (0)1 45 12 35 35
Germany +49 (0)761 1 56 47 0
Israel +972 (0)3 6124242
Italy +39 043 855 5573
Spain +34 93 846 05 43

©2012 Zimmer Dental Inc. All rights reserved. 5161, Rev. 3/12.
SimPlant is a registered trademark of Materialise Dental NV. SimPlant software is distributed by Zimmer Dental Inc. Please note that not all products and regenerative materials are registered or available in every country/region. Please check with a Zimmer Dental representative for availability and additional information.

To receive our eNews visit us at http://www.zimmerdental.com/news_eNewsletterSignUp.aspx



www.zimmerdental.com